



MULTI VTM **5** **575V** **ENGINEERING MANUAL**

Variable Refrigerant Flow Outdoor Units
6.0 to 42.0 Tons



PROPRIETARY DATA NOTICE

**This document, as well as all reports, illustrations, data, information, and other materials are the property of LG Electronics Canada, Inc., and are disclosed by LG Electronics Canada, Inc. only in confidence.
This document is for design purposes only.**





A summary list of safety precautions is on page 3.

To access additional technical documentation such as submittals, indoor unit engineering manuals, installation, service, product data performance, general best practice, and building ventilation manuals, as well as white papers, catalogs, LATS software programs, and more, log in to www.lgvrf.ca.

TABLE OF CONTENTS

Unit Nomenclature.....	4
LG Air Conditioner Technical Solution (LATS).....	5-6
LG Air Conditioner Technical Solution (LATS).....	7
Outdoor Unit Product Data.....	8-62
<i>Mechanical Specifications</i>	<i>9-10</i>
<i>Features</i>	<i>10</i>
<i>General Data</i>	<i>11-15</i>
<i>Electrical Data</i>	<i>16</i>
<i>Connection Limitations.....</i>	<i>17</i>
<i>Dimensions.....</i>	<i>18-20</i>
<i>Wiring Diagrams</i>	<i>21-23</i>
<i>Refrigerant Flow Diagrams.....</i>	<i>24-49</i>
<i>Acoustic Data</i>	<i>50-55</i>
<i>Accessories</i>	<i>56-62</i>
Electrical Connections	63-66
<i>System for Heat Pump Operation</i>	<i>64</i>
<i>System for Heat Recovery Operation</i>	<i>65</i>
<i>DIP Switch Settings For Use With Gen 4 Indoor Units.....</i>	<i>66</i>
Placement Considerations	67-81
<i>Piping Limitations</i>	<i>68-73</i>
<i>Refrigerant Piping for Separated Outdoor Units</i>	<i>74-76</i>
<i>Selecting the Best Location for Outdoor Unit(s).....</i>	<i>77-78</i>
<i>Outdoor Unit Clearance Requirements.....</i>	<i>79-80</i>
<i>Installing Outdoor Units Indoors.....</i>	<i>80-81</i>

TABLE OF SYMBOLS

 DANGER	<i>This symbol indicates an imminently hazardous situation which, if not avoided, will result in death or serious injury.</i>
 WARNING	<i>This symbol indicates a potentially hazardous situation which, if not avoided, could result in death or serious injury.</i>
 CAUTION	<i>This symbol indicates a potentially hazardous situation which, if not avoided, may result in minor or moderate injury.</i>
Note:	<i>This symbol indicates situations that may result in equipment or property damage accidents only.</i>
	<i>This symbol indicates an action that should not be performed.</i>

UNIT NOMENCLATURE

Outdoor Units and Heat Recovery Units

Outdoor Units (ODU)

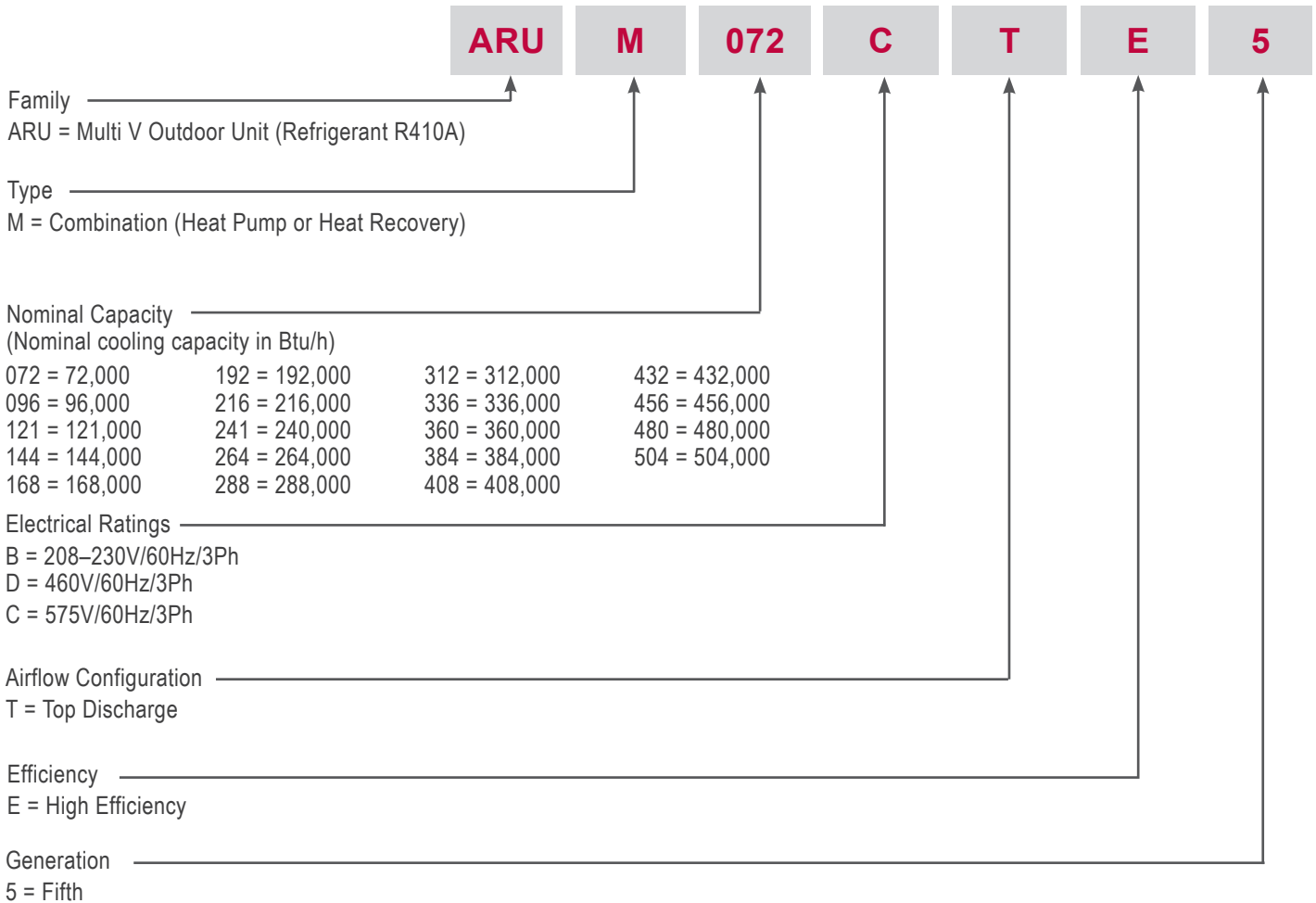

Note:

For Heat Recovery Unit information, refer to the applicable Engineering Manual on www.lgvrf.ca

LG Air Conditioner Technical Solution (LATS) Software

A properly designed and installed refrigerant piping system is critical to the optimal performance of LG air-conditioning systems. To assist engineers, LG offers, free of charge, LG Air Conditioner Technical Solution (LATS) software—a total design solution for LG air conditioning systems.

Note:

To reduce the risk of designing an improper applied system or one that will not operate correctly, LG requires that LATS software be used on all projects.

Formats

LATS is available to LG customers in three user interfaces: LATS HVAC, LATS CAD, and LATS REVIT. All three LATS formats are available through www.myLGHVAC.com, or contact an LG Sales Representative.

LATS HVAC is a Windows®-based application that aids engineers in designing LG Variable Refrigerant Flow (VRF), Multi F / Multi F MAX, Single-Zone, and Energy Recovery Ventilator (ERV) systems.

*Windows® is a registered mark of Microsoft® Corporation.

LATS CAD combines the LG LATS program with AutoCAD® software**. It permits engineers to layout and validate LG Multi V Variable Refrigerant Flow (VRF), Multi F / Multi F MAX, Single-Zone, and Energy Recovery Ventilator (ERV) systems directly into CAD drawings.

LATS Revit integrates the LG LATS program with Revit® software**. It permits engineers to layout and validate Multi V VRF systems directly into Revit drawings.

**AutoCAD® and Revit® are both registered marks of Autodesk, Inc.

Features

All LG product design criteria have been loaded into the program, making LATS simple to use: double click or drag and drop the component choices. Build systems in Tree Mode where the refrigerant system can be viewed. Switch to a Schematic diagram to see the electrical and communications wiring.

LATS software permits the user to input region data, indoor and outdoor design temperatures, modify humidity default values, zoning, specify type and size of outdoor units and indoor units, and input air flow and external static pressure (ESP) for ducted indoor units.

The program can also:

- Import building loads from a separate Excel file.
- Present options for outdoor unit auto selection.
- Automatically calculate component capacity based on design conditions for the chosen region.
- Verify if the height differences between the various system components are within system limits.
- Provide the correct size of each refrigerant piping segment and LG Y-Branched and Headers.
- Adjust overall piping system length when elbows are added.
- Check for component piping limitations and flag if any parameters are broken.
- Factor operation and capacity for defrost operation.
- Calculate refrigerant charge, noting any additional trim charge.
- Suggest accessories for indoor units and outdoor units.
- Run system simulation.

Note:

Features depend on which LATS program is being used, and the type of system being designed.

Figure 1: Example of LATS CAD2.



LG AIR CONDITIONER TECHNICAL SOLUTION (LATS)

MULTI V 5

LATS Generates a Complete Project Report

LATS software also generates a report containing project design parameters, cooling and heating design data, system component performance, and capacity data. The report includes system combination ratio and refrigerant charge calculations; and provides detailed bill of material, including outdoor units, indoor units, control devices, accessories, refrigerant pipe sizes segregated by building, by system, by pipe size, and by pipe segments.

Proper Design to Install Procedure

LG encourages a two report design-to-install-procedure. After the design engineer determines building / zone loads and other details, the engineer opens the LATS program and inputs the project's information. When the design is complete, the "Auto Piping" and "System Check" functions should be used to verify piping sizes, limitations, and if any design errors are present. If errors are found, engineers should adjust the design, and run Auto Piping and System Check again. When the design passes the checks, then the engineer prints out a project "Shop Drawing" (LATS Tree Diagram) and provides it to the installing contractor. The contractor should follow the LATS Tree Diagram when building the piping system, but oftentimes the design changes on the building site:

- Architect has changed location and/or purpose of room(s).
- Outdoor unit cannot be placed where originally intended.
- Structural elements prevent routing the piping as planned.
- Air conditioning system conflicts with other building systems (plumbing, gas lines, etc.).

Figure 2: Example of a LATS Tree Diagram.

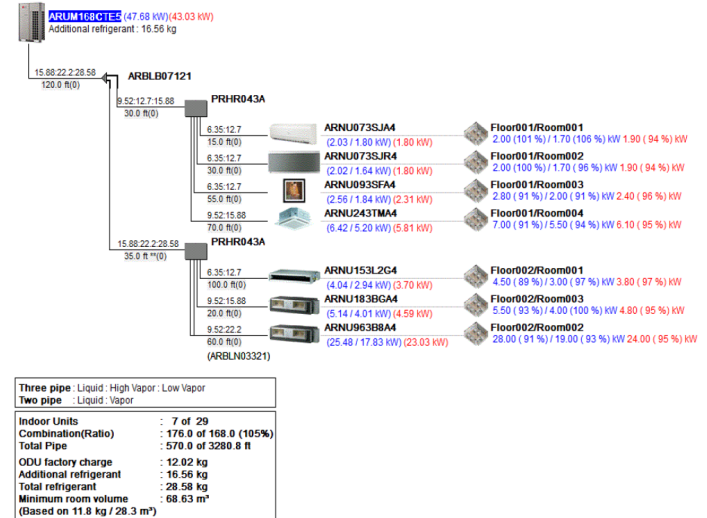

The contractor must mark any deviation from the design on the Shop Drawing, including as-built straight lines and elbows. This "Mark Up" drawing should be returned to the design engineer or Rep, who should input contractor changes into the LATS file. (Copy the original LATS software file, save and rename as a separate file, and modify all piping lengths by double-clicking on each length and editing information.) Like the shop drawing, the Auto Piping and System Check should also be run on this new "As Built" drawing. The design engineer or Rep must then provide the final As Built file to the contractor. The Mark Up version must be compared to the As Built version for:

- Differences in pipe diameter(s). If incorrect diameters have been installed, the piping must be changed out. If pipe diameters have changed, check to see if Y-Branches will also need to be changed.
- Changes to outdoor unit and indoor unit capacities. Capacities changes may impact line length changes.
- Additional refrigerant charge quantity ("Trim Charge"). Trim charge will change if piping lengths and diameters change. The As Built version must reflect installed piping lengths to ensure correct trim charge.

All documents submitted by the contractor, as well as the Shop Drawing and the As Built Drawing files must be provided for commissioning purposes. Model and serial numbers for all system components must also be submitted. If the steps previously detailed are not followed, and all documents are not provided to the commissioning agent, the project runs the risk of not being commissioned and voiding any limited warranty LG offers on the equipment.

MULTI VTM 5 REFRIGERANT CHARGE WORKSHEET

System R410A Refrigerant Charge Calculator (lbs.)

System Tag or ID:		Job Name: _____				
		Project Manager: _____			Date: _____	
Line #	Description	Chassis I.D.	Size	Quantity	CF (Ref.) ¹	Total (lbs.)
1	Linear feet of 1/4" liquid line tubing ²	—	—		0.015	
2	Linear feet of 3/8" liquid line tubing ²	—	—		0.041	
3	Linear feet of 1/2" liquid line tubing ²	—	—		0.079	
4	Linear feet of 5/8" liquid line tubing ²	—	—		0.116	
5	Linear feet of 3/4" liquid line tubing ²	—	—		0.179	
6	Linear feet of 7/8" liquid line tubing ²	—	—		0.238	
7	Linear feet of 1" liquid line tubing ²	—	—		0.323	
8	Standard + Art Cool Mirror	SJ, SK	5k to 15k		0.53	
9	Standard + Art Cool Mirror	SJ, SK	18k to 24k		0.62	
10	Standard	SV	30k to 36k		1.01	
11	Art Cool Gallery	SF	9k to 12k		0.22	
12	1-Way Cassette	TU	7k to 12k		0.44	
13	1-Way Cassette	TT	18k to 24k		0.64	
14	2-Way Cassette	TS	18k to 24k		0.75	
15	4-Way 2' x 2' Cassette	TR	5k to 7k		0.40	
16	4-Way 2' x 2' Cassette	TR	9k to 12k		0.55	
17	4-Way 2' x 2' Cassette	TQ	15k to 18k		0.71	
18	4-Way 3' x 3' Cassette	TN	7k to 24k		0.88	
19	4-Way 3' x 3' Cassette	TN	36k		1.41	
20	4-Way 3' x 3' Cassette	TM	24k to 36k		1.08	
21	4-Way 3' x 3' Cassette	TM	42k to 48k		1.41	
22	4-Way 3' x 3' Cassette	TP	24k to 28k		1.06	
23	High Static Ducted	BH	7k to 24k		0.57	
24	High Static Ducted	BG	7k to 42k		0.97	
25	High Static Ducted	BR	28k to 54k		1.37	
26	High Static Ducted	B8	36k to 96k		2.20	
27	Low Static Ducted, Low Static Ducted Bottom Return	L1	5k to 9k		0.31	
28	Low Static Ducted, Low Static Ducted Bottom Return	L2	12k to 18k		0.42	
29	Low Static Ducted, Low Static Ducted Bottom Return	L3	21k to 24k		0.55	
30	Vertical / Horizontal Air Handling Unit	NJ	12k to 30k		1.04	
31	Vertical / Horizontal Air Handling Unit	NJ	36k		1.57	
32	Vertical / Horizontal Air Handling Unit	NK	42k to 54k		2.00	
33	Floor Standing	CE (U)	7k to 15k		0.37	
34	Floor Standing	CF (U)	18k to 24k		0.82	
35	HRU: PRHR022A/023A, 032A/033A, 042A/043A	-	-	-	1.1	
36	HRU : PRHR063A, 083A	-	-	-	2.2	
37	ADDITIONAL Refrigerant Charge Required (Sum of lines 1 – 35)					
38	Outdoor Unit Factory Refrigerant Charge	37A	ARUM072*TE5	72k		14.3
		37B	ARUM096*TE5	96k		23.2
		37C	ARUM121*TE5	121k		23.2
		37D	ARUM144*TE5	144k		26.5
		37E	ARUM168*TE5	168k		26.5
		37F	ARUM192*TE5	192k		30.9
		37G	ARUM216*TE5	216k		37.5
		37H	ARUM241*TE5	241k		37.5
39	Total ODU FACTORY Refrigerant Charge (Sum of factory refrigerant charges for all ODUs in the system)					
40	TOTAL SYSTEM CHARGE					
	Sum of Additional Refrigerant Charge Required (line 36) and Total ODU Factory Refrigerant Charge (line 42)					

Introduction

¹CF (Ref.) = Correction Factor for Refrigerant Charge. ²For refrigerant charge purposes, consider only the liquid line; ignore the vapor line(s).



OUTDOOR UNIT PRODUCT DATA

Mechanical Specifications on page 9

Features on page 10

General Data on page 11

Electrical Data on page 16

Connection Limitations on page 17

Dimensions on page 18

Wiring Diagrams on page 21

Refrigerant Flow Diagrams on page 24

Acoustic Data on page 50

Accessories on page 56

Multi V 5 Outdoor Units

General

LG Multi V 5 Variable Refrigerant Flow (VRF) outdoor unit can be configured to operate as a Heat Pump system or a Heat Recovery System. Single, dual, or triple frame outdoor unit combinations are connected to indoor units with a single refrigerant piping system using factory designed and supplied Y-branches, Headers, and/or Heat Recovery Units and have integrated controls.

The system is capable of being designed for minimum piping and maximum design flexibility. Each Heat Recovery Unit piping port is independently capable of operating in either heating or cooling mode regardless of the mode of other piping ports on the same heat recovery unit or in the system. The Heat Recovery Unit is capable of changing mode of individual indoor units or zones (cooling to heating or heating to cooling) within a maximum time frame of three (3) minutes to ensure indoor temperature can be properly maintained.

LG components are manufactured in a facility registered to ISO 9001 and ISO 14001, which is a set of standards applying to environmental protection set by the International Organization for Standardization (ISO). The units are Electrical Testing Laboratories (ETL) listed and bear the ETL label. All internal wiring is in accordance with the National Electrical Code (NEC).



Temperature Ranges

Heat Pump Configuration

In Heat Pump configuration, the system can operate in heating only mode (i.e. all indoor units in heating mode) from -22°F to 61°F outdoor ambient wet bulb. Heat Pump systems can operate in cooling mode from 5°F to 122°F outdoor ambient dry bulb. Optional low ambient cooling kit extends the cooling only operating range (i.e., all indoor units in cooling mode) down to -9.9°F. See the Multi V 5 Installation Manual for DIP switch settings for Heat Pump operation.

Heat Recovery Configuration

In Heat Recovery configuration, the system can operate in heating only mode (i.e. all indoor units in heating mode) from -22°F to 61°F outdoor ambient wet bulb. Heat Recovery systems can operate in cooling only mode from 5°F to 122°F outdoor ambient dry bulb. Optional low ambient cooling kit extends cooling only operation range (i.e. all indoor units in cooling mode) down to -9.9°F. Heat Recovery synchronous operation range is 14°F to 81°F outdoor ambient dry bulb. See the Multi V 5 Installation Manual for DIP switch settings for Heat Recovery operation.

Casing / Frame

Outdoor units are constructed with galvanized steel, bonderized and finished with baked enamel paint. Each frame has a removable inspection panel to allow access to service tool connections, DIP switches, auto addressing, and error codes. The entire front panel of the outdoor unit is removable for maintenance.

Outdoor unit frames are completely factory assembled, piped and wired. Dual and triple frame outdoor units are field piped with factory designed and supplied outdoor unit Y-branch kits to manifold them together into a single refrigerant circuit.

Refrigerant System

The refrigeration system consists of a single refrigeration circuit and uses R410A refrigerant. The outdoor unit is provided with factory installed components, including a refrigerant strainer, check valves, oil separator, oil level sensor, accumulator, four-way reversing valves, electronically controlled expansion valve (EEV), high and low side charging ports, high pressure safety switch, service valves, and interconnecting piping. Also included is an integral subcooler assembly consisting of a double spiral tube-type subcooling heat exchanger and EEV providing modulation of up to 23°F subcooling.

Compressors

All 3-phase outdoor unit frames ≤130MBh nominal capacity are equipped with one digitally controlled inverter-driven hermetic scroll compressor to modulate capacity (variable from 12 to 150Hz). All 3-phase outdoor unit frames ≥130MBh nominal capacity are equipped with two digitally controlled inverter-driven hermetic scroll compressors to modulate capacity (variable from 12 to 150Hz). An internal thermal overload, and a factory-mounted 60 watt crankcase heater are included on all compressors.

Outdoor Unit Coil

The outdoor unit coils are of a nonferrous construction with louvered aluminum fins on copper tubing, and are protected by a metal guard. Coil fins have a factory applied corrosion resistant Black Fin™ and hydrophilic coating.

Fans and Motors

All outdoor unit frames (575V) include two direct drive, variable speed, biomimetic enhanced, propeller type fans. All fan motors have inherent protection, permanently lubricated bearings, and are variable speed with a maximum speed up to 1,150 rpm. Fan guards are provided to limit contact with moving parts. All Heat Pump / Heat Recovery outdoor units have vertical discharge airflow. Optional air guides can be field installed to change discharge airflow from vertical to horizontal. Outdoor units have an additional static pressure capability up to 0.32" WG with a DIP switch setting.

Electrical

Outdoor units are available in 575V/60 Hz/3-phase. The unit controls include current protection logic.

Controls

Outdoor units are factory wired with necessary electrical control components, integral microprocessors, printed circuit boards, thermistors, sensors, terminal blocks, and lugs for power wiring.

The control circuit between the indoor units, heat recovery units, and outdoor unit is a variable low voltage DC communication completed using a two conductor, stranded, and shielded cable for the RS-485 daisy chain communication wiring. Microprocessor-based algorithms provide component protection, soft-start capability, refrigeration system pressure, temperature, defrost, and ambient control.

Note:

See the Heat Recovery Unit Product Section for heat recovery unit mechanical specifications.

System Features

Advanced Smart Load Control

Automatically adjusts system target pressures based on outdoor temperature and humidity for increased cooling and heating performance.

Intelligent Heating

By monitoring the outdoor ambient humidity, the target high refrigerant pressure and compressor frequency can be reduced to extend heating operation, delay defrost operation initialization, and reduce power consumption.

Comfort Cooling

By monitoring the indoor temperature and setpoint differential, the target indoor unit refrigerant superheat and flow rate can be adjusted for improved comfort and cooling efficiency.

HiPOR™ (High Pressure Oil Return)

Refrigerant oil is captured from the compressor discharge by the centrifugal oil separator and then returned to the compressor through a separate oil injection pipe, preventing efficiency loss inherent in returning oil to the suction side of the compressor.

Smart Oil Control

Actively monitors the oil level inside each compressor and only initiates an oil return cycle to flush oil in the piping system back to the compressor oil sump when the oil level is too low, preventing the need for timed oil return cycles while maintaining proper oil level.

Active Refrigerant Control

Depending on the operating mode and conditions, the system refrigerant level is automatically adjusted for increased part load and heating operation efficiency.

Variable Path Heat Exchanger

Depending on the operating mode and conditions, both the refrigerant flow path and velocity are adjusted automatically for improved efficiency.

Vapor Injection

In heating mode, warm refrigerant vapor discharged by the subcooling heat exchanger is injected into the compressor scroll chamber, improving heating performance at low outdoor ambient conditions.

Advanced PCB Cooling

Improved cooling performance of the inverter drive control board by using liquid refrigerant instead of heat pipe or heat sink cooling methods using outdoor fan airflow.

Table 1: Single Frame 575V Outdoor Units.

Unit Model Number	ARUM072CTE5 6.0 Ton	ARUM096CTE5 8.0 Ton	ARUM121CTE5 10.0 Ton	ARUM144CTE5 12.0 Ton
Individual Component Model Numbers	-	-	-	-
Cooling Performance				
Nominal Cooling Capacity (Btu/h) ¹	72,000	96,000	119,700	144,000
Rated Cooling Capacity (Btu/h) ²	69,000	92,000	114,000	138,000
Heating Performance				
Nominal Heating Capacity (Btu/h) ¹	81,000	108,000	135,000	162,000
Rated Heating Capacity (Btu/h) ²	77,000	103,000	129,000	154,000
Operating Range				
Cooling (°F DB)	5 to 122	5 to 122	5 to 122	5 to 122
Heating (°F WB)	-22 to +61	-22 to +61	-22 to +61	-22 to +61
Synchronous — Cooling Based (°F DB)	14 to 81	14 to 81	14 to 81	14 to 81
Synchronous — Heating Based (°F WB)	14 to 61	14 to 61	14 to 61	14 to 61
Compressor				
Inverter Quantity	HSS DC Scroll x 1	HSS DC Scroll x 1	HSS DC Scroll x 1	HSS DC Scroll x 2
Oil/Type	PVE / FVC68D	PVE / FVC68D	PVE / FVC68D	PVE / FVC68D
Fan (Top Discharge)				
Type	Propeller (BLDC)	Propeller (BLDC)	Propeller (BLDC)	Propeller (BLDC)
Motor Output (kW) x Qty.	0.9 x 2	0.9 x 2	0.9 x 2	0.9 x 2
Motor/Drive	Brushless Digitally Controlled / Direct			
Operating Range (RPM)	Cooling	0 - 1,150	0 - 1,150	0 - 1,150
	Heating	80 - 1,150	80 - 1,150	80 - 1,150
Maximum Air Volume (CFM)	11,300	11,300	11,300	11,300
Unit Data				
Refrigerant Type	R410A	R410A	R410A	R410A
Refrigerant Control/Location	EEV / Indoor Unit	EEV / Indoor Unit	EEV / Indoor Unit	EEV / Indoor Unit
Factory Charge lbs. of R410A	23.2	23.2	23.2	26.5
Max. No. Indoor Units/System ³	13	16	20	23
Sound Pressure dB(A) ⁴	58.0	58.0	59.0	60.0
Net Unit Weight (lbs.)	507	507	507	639
Shipping Weight (lbs.)	534	534	534	666
Communication Cables ^{5,6}	2 x 18	2 x 18	2 x 18	2 x 18
Heat Exchanger				
Material and Fin Coating	Copper Tube / Aluminum Fin and Black Coated Fin™ / Hydrophilic			
Rows/Fins per inch	2 / 17	2 / 17	2 / 17	3 / 17
Piping for Heat Recovery Operation⁷				
Liquid Line Connection (in., OD)	3/8 Braze	3/8 Braze	1/2 Braze	1/2 Braze
Low Pressure Vapor Line Connection (in., OD)	3/4 Braze	7/8 Braze	1-1/8 Braze	1-1/8 Braze
High Pressure Vapor Line Connection (in., OD)	3/4 Braze	3/4 Braze	7/8 Braze	7/8 Braze
Piping for Heat Pump Operation⁷				
Liquid Line Connection (in., OD)	3/8 Braze	3/8 Braze	1/2 Braze	1/2 Braze
Vapor Line Connection (in., OD)	3/4 Braze	7/8 Braze	1-1/8 Braze	1-1/8 Braze

¹Nominal capacity applied with non-ducted indoor units, and is rated 0 ft. above sea level with 25 ft. of refrigerant line per indoor unit and a 0 ft. level difference between outdoor and indoor units. All capacities are net with a Combination Ratio between 95–105%.

Nominal cooling capacity rating obtained with air entering the indoor unit at 80°F dry bulb (DB) and 67°F wet bulb (WB) and outdoor ambient conditions of 95°F dry bulb (DB) and 75°F wet bulb (WB).

Nominal heating capacity rating obtained with air entering the indoor unit at 70°F dry bulb (DB) and 59°F wet bulb (WB) and outdoor ambient conditions of 47°F dry bulb (DB) and 43°F wet bulb (WB).

²Rated capacity is certified under AHRI Standard 1230. See www.ahrinet.org for information.

³The System Combination Ratio must be between 50–130%.

⁴Sound pressure levels are tested in an anechoic chamber under ISO Standard 3745.

⁵Communication cable between Master ODU to Slave ODU(s), and Master ODU to IDUs / HRUs to be 18 AWG, 2-conductor, twisted, stranded, shielded. Ensure the communication cable shield is properly grounded to the Master ODU chassis only. Do not ground the ODU to IDUs / HRUs communication cable at any other point. Wiring must comply with all applicable local and national codes.

⁶Power wiring is field provided, solid or stranded, and must comply with the applicable local and national codes. See page 15 for detailed electrical data.

⁷LG requires that LATS software be used on all projects to ensure correct line sizing. Designer must verify the shop drawing design against the as built design using LATS. Contractor must also use LG manufactured Y-Branch and Header Kits only.

GENERAL DATA



575V Outdoor Unit Specifications

Table 2: Single Frame 575V Outdoor Units, continued.

Unit Model Number	ARUM168CTE5 14.0 Ton	ARUM192CTE5 16.0 Ton	ARUM216CTE5 18.0 Ton	ARUM241CTE5 20.0 Ton
Individual Component Model Numbers	-	-	-	-
Cooling Performance				
Nominal Cooling Capacity (Btu/h) ¹	168,000	192,000	216,000	233,100
Rated Cooling Capacity (Btu/h) ²	160,000	184,000	206,000	222,000
Heating Performance				
Nominal Heating Capacity (Btu/h) ¹	189,000	216,000	243,000	243,000
Rated Heating Capacity (Btu/h) ²	180,000	206,000	230,000	230,000
Operating Range				
Cooling (°F DB)	5 to 122	5 to 122	5 to 122	5 to 122
Heating (°F WB)	-22 to +61	-22 to +61	-22 to +61	-22 to +61
Synchronous — Cooling Based (°F DB)	14 to 81	14 to 81	14 to 81	14 to 81
Synchronous — Heating Based (°F WB)	14 to 61	14 to 61	14 to 61	14 to 61
Compressor				
Inverter Quantity	HSS DC Scroll x 2	HSS DC Scroll x 2	HSS DC Scroll x 2	HSS DC Scroll x 2
Oil/Type	PVE / FVC68D	PVE / FVC68D	PVE / FVC68D	PVE / FVC68D
Fan (Top Discharge)				
Type	Propeller (BLDC)	Propeller (BLDC)	Propeller (BLDC)	Propeller (BLDC)
Motor Output (kW) x Qty.	0.9 x 2	0.9 x 2	0.9 x 2	0.90 x 2
Motor/Drive	Brushless Digitally Controlled / Direct			
Operating Range (RPM)	Cooling	0 - 1,150	0 - 1,150	0 - 1,150
	Heating	80 - 1,150	80 - 1,150	80 - 1,150
Maximum Air Volume (CFM)	11,300	11,300	11,300	11,300
Unit Data				
Refrigerant Type	R410A	R410A	R410A	R410A
Refrigerant Control/Location	EEV / Indoor Unit	EEV / Indoor Unit	EEV / Indoor Unit	EEV / Indoor Unit
Factory Charge lbs. of R410A	26.5	30.9	37.5	37.5
Max. No. Indoor Units/System ³	26	29	32	35
Sound Pressure dB(A) ⁴	61.0	62.0	64.0	65.0
Net Unit Weight (lbs.)	639	659	666	666
Shipping Weight (lbs.)	666	688	694	694
Communication Cables ^{5,6}	2 x 18	2 x 18	2 x 18	2 x 18
Heat Exchanger				
Material and Fin Coating	Copper Tube / Aluminum Fin and Black Coated Fin™ / Hydrophilic			
Rows/Fins per inch	3 / 17	3 / 17	3 / 17	3 / 17
Piping for Heat Recovery Operation⁷				
Liquid Line Connection (in., OD)	5/8 Braze	5/8 Braze	5/8 Braze	5/8 Braze
Low Pressure Vapor Line Connection (in., OD)	1-1/8 Braze	1-1/8 Braze	1-1/8 Braze	1-3/8 Braze
High Pressure Vapor Line Connection (in., OD)	7/8 Braze	1-1/8 Braze	1-1/8 Braze	1-1/8 Braze
Piping for Heat Pump Operation⁷				
Liquid Line Connection (in., OD)	5/8 Braze	5/8 Braze	5/8 Braze	5/8 Braze
Vapor Line Connection (in., OD)	1-1/8 Braze	1-1/8 Braze	1-1/8 Braze	1-3/8 Braze

¹Nominal capacity applied with non-ducted indoor units, and is rated 0 ft. above sea level with 25 ft. of refrigerant line per indoor unit and a 0 ft. level difference between outdoor and indoor units. All capacities are net with a Combination Ratio between 95–105%.

Nominal cooling capacity rating obtained with air entering the indoor unit at 80°F dry bulb (DB) and 67°F wet bulb (WB) and outdoor ambient conditions of 95°F dry bulb (DB) and 75°F wet bulb (WB).

Nominal heating capacity rating obtained with air entering the indoor unit at 70°F dry bulb (DB) and 59°F wet bulb (WB) and outdoor ambient conditions of 47°F dry bulb (DB) and 43°F wet bulb (WB).

²Rated capacity is certified under AHRI Standard 1230. See www.ahrinet.org for information.

³The System Combination Ratio must be between 50–130%.

⁴Sound pressure levels are tested in an anechoic chamber under ISO Standard 3745.

⁵Communication cable between Master ODU to Slave ODU(s), and Master ODU to IDUs / HRUs to be 18 AWG, 2-conductor, twisted, stranded, shielded. Ensure the communication cable shield is properly grounded to the Master ODU chassis only. Do not ground the ODU to IDUs / HRUs communication cable at any other point. Wiring must comply with all applicable local and national codes.

⁶Power wiring is field provided, solid or stranded, and must comply with the applicable local and national codes. See page 15 for detailed electrical data.

⁷LG requires that LATS software be used on all projects to ensure correct line sizing. Designer must verify the shop drawing design against the as built design using LATS. Contractor must also use LG manufactured Y-Branch and Header Kits only.

Table 3: Dual Frame 575V Outdoor Units.

Unit Model Number	ARUM264CTE5 22.0 Ton	ARUM288CTE5 24.0 Ton	ARUM312CTE5 26.0 Ton	ARUM336CTE5 28.0 Ton
Individual Component Model Numbers	ARUM096CTE5 + ARUM168CTE5	ARUM096CTE5 + ARUM192CTE5	ARUM096CTE5 + ARUM216CTE5	ARUM121CTE5 + ARUM216CTE5
Cooling Performance				
Nominal Cooling Capacity (Btu/h) ¹	264,000	288,000	312,000	336,000
Rated Cooling Capacity (Btu/h) ²	252,000	276,000	298,000	320,000
Heating Performance				
Nominal Heating Capacity (Btu/h) ¹	297,000	324,000	351,000	378,000
Rated Heating Capacity (Btu/h) ²	283,000	309,000	333,000	359,000
Operating Range				
Cooling (°F DB)	5 to 122	5 to 122	5 to 122	5 to 122
Heating (°F WB)	-22 to +61	-22 to +61	-22 to +61	-22 to +61
Synchronous — Cooling Based (°F DB)	14 to 81	14 to 81	14 to 81	14 to 81
Synchronous — Heating Based (°F WB)	14 to 61	14 to 61	14 to 61	14 to 61
Compressor				
Inverter Quantity	HSS DC Scroll x 3	HSS DC Scroll x 3	HSS DC Scroll x 3	HSS DC Scroll x 3
Oil/Type	PVE / FVC68D	PVE / FVC68D	PVE / FVC68D	PVE / FVC68D
Fan (Top Discharge)				
Type	Propeller (BLDC)	Propeller (BLDC)	Propeller (BLDC)	Propeller (BLDC)
Motor Output (kW) x Qty.	0.90 x 2 + 0.90 x 2	0.90 x 2 + 0.90 x 2	0.90 x 2 + 0.90 x 2	0.90 x 2 + 0.90 x 2
Motor/Drive	Brushless Digitally Controlled / Direct			
Operating Range (RPM)	Cooling	0 - 1,150	0 - 1,150	0 - 1,150
	Heating	80 - 1,150	80 - 1,150	80 - 1,150
Maximum Air Volume (CFM)	22,600	22,600	22,600	22,600
Unit Data				
Refrigerant Type	R410A	R410A	R410A	R410A
Refrigerant Control/Location	EEV / Indoor Unit	EEV / Indoor Unit	EEV / Indoor Unit	EEV / Indoor Unit
Factory Charge lbs. of R410A	23.2 + 26.5	23.2 + 30.9	23.2 + 37.5	23.2 + 37.5
Max. No. Indoor Units/System ³	39	42	45	49
Sound Pressure dB(A) ⁴	63.0	63.0	65.0	65.0
Net Unit Weight (lbs.)	507 + 639	507 + 659	507 + 666	507 + 666
Shipping Weight (lbs.)	534 + 666	534 + 688	534 + 694	534 + 694
Communication Cables ^{5,6}	2 x 18	2 x 18	2 x 18	2 x 18
Heat Exchanger				
Material and Fin Coating	Copper Tube / Aluminum Fin and Black Coated Fin™ / Hydrophilic			
Rows/Fins per inch	2 / 17 + 3 / 17	2 / 17 + 3 / 17	2 / 17 + 3 / 17	2 / 17 + 3 / 17
Piping for Heat Recovery Operation⁷				
Liquid Line Connection (in., OD)	3/8 & 5/8 Braze	3/8 & 5/8 Braze	3/8 & 5/8 Braze	1/2 & 5/8 Braze
Low Pressure Vapor Line Connection (in., OD)	7/8 & 1-1/8 Braze	7/8 & 1-1/8 Braze	7/8 & 1-1/8 Braze	1-1/8 & 1-1/8 Braze
High Pressure Vapor Line Connection (in., OD)	3/4 & 7/8 Braze	3/4 & 1-1/8 Braze	3/4 & 1-1/8 Braze	7/8 & 1-1/8 Braze
Piping for Heat Pump Operation⁷				
Liquid Line Connection (in., OD)	3/8 & 5/8 Braze	3/8 & 5/8 Braze	3/8 & 5/8 Braze	1/2 & 5/8 Braze
Vapor Line Connection (in., OD)	7/8 & 1-1/8 Braze	7/8 & 1-1/8 Braze	7/8 & 1-1/8 Braze	1-1/8 & 1-1/8 Braze

¹Nominal capacity applied with non-ducted indoor units, and is rated 0 ft. above sea level with 25 ft. of refrigerant line per indoor unit and a 0 ft. level difference between outdoor and indoor units. All capacities are net with a Combination Ratio between 95–105%.

Nominal cooling capacity rating obtained with air entering the indoor unit at 80°F dry bulb (DB) and 67°F wet bulb (WB) and outdoor ambient conditions of 95°F dry bulb (DB) and 75°F wet bulb (WB).
Nominal heating capacity rating obtained with air entering the indoor unit at 70°F dry bulb (DB) and 59°F wet bulb (WB) and outdoor ambient conditions of 47°F dry bulb (DB) and 43°F wet bulb (WB).

²Rated capacity is certified under AHRI Standard 1230. See www.ahrinet.org for information.

³The System Combination Ratio must be between 50–130%.

⁴Sound pressure levels are tested in an anechoic chamber under ISO Standard 3745.

⁵Communication cable between Master ODU to Slave ODU(s), and Master ODU to IDUs / HRUs to be 18 AWG, 2-conductor, twisted, stranded, shielded. Ensure the communication cable shield is properly grounded to the Master ODU chassis only. Do not ground the ODU to IDUs / HRUs communication cable at any other point. Wiring must comply with all applicable local and national codes.

⁶Power wiring is field provided, solid or stranded, and must comply with the applicable local and national codes. See page 15 for detailed electrical data.

⁷LG requires that LATS software be used on all projects to ensure correct line sizing. Designer must verify the shop drawing design against the as built design using LATS. Contractor must also use LG manufactured Y-Branch and Header Kits only.

575V Outdoor Unit Specifications

Table 4: Dual Frame 575V Outdoor Units, continued.

Combination Unit Model Number	ARUM360CTE5 30.0 Ton	ARUM384CTE5 32.0 Ton	ARUM408CTE5 34.0 Ton
Individual Component Model Numbers	ARUM144CTE5 + ARUM216CTE5	ARUM168CTE5 + ARUM216CTE5	ARUM192CTE5 + ARUM216CTE5
Cooling Performance			
Nominal Cooling Capacity (Btu/h) ¹	360,000	384,000	408,000
Rated Cooling Capacity (Btu/h) ²	344,000	366,000	390,000
Heating Performance			
Nominal Heating Capacity (Btu/h) ¹	405,000	432,000	459,000
Rated Heating Capacity (Btu/h) ²	384,000	410,000	436,000
Operating Range			
Cooling (°F DB)	5 to 122	5 to 122	5 to 122
Heating (°F WB)	-22 to +61	-22 to +61	-22 to +61
Synchronous — Cooling Based (°F DB)	14 to 81	14 to 81	14 to 81
Synchronous — Heating Based (°F WB)	14 to 61	14 to 61	14 to 61
Compressor			
Inverter Quantity	HSS DC Scroll x 4	HSS DC Scroll x 4	HSS DC Scroll x 4
Oil/Type	PVE / FVC68D	PVE / FVC68D	PVE / FVC68D
Fan (Top Discharge)			
Type	Propeller (BLDC)	Propeller (BLDC)	Propeller (BLDC)
Motor Output (kW) x Qty.	0.90 x 2 + 0.90 x 2	0.90 x 2 + 0.90 x 2	0.90 x 2 + 0.90 x 2
Motor/Drive	Brushless Digitally Controlled / Direct		
Operating Range (RPM)	Cooling	0 - 1,150	0 - 1,150
	Heating	80 - 1,150	80 - 1,150
Maximum Air Volume (CFM)	22,600	22,600	22,600
Unit Data			
Refrigerant Type	R410A	R410A	R410A
Refrigerant Control/Location	EEV / Indoor Unit	EEV / Indoor Unit	EEV / Indoor Unit
Factory Charge lbs. of R410A	26.5 + 37.5	26.5 + 37.5	30.9 + 37.5
Max. No. Indoor Units/System ³	52	55	58
Sound Pressure dB(A) ⁴	66.0	66.0	66.0
Net Unit Weight (lbs.)	639 + 666	639 + 666	659 + 666
Shipping Weight (lbs.)	666 + 694	666 + 694	688 + 694
Communication Cables ^{5,6}	2 x 18	2 x 18	2 x 18
Heat Exchanger			
Material and Fin Coating	Copper Tube / Aluminum Fin and Black Coated Fin™ / Hydrophilic		
Rows/Fins per inch	3 / 17 x 2	3 / 17 x 2	3 / 17 x 2
Piping for Heat Recovery Operation⁷			
Liquid Line Connection (in., OD)	1/2 & 5/8 Braze	5/8 & 5/8 Braze	5/8 & 5/8 Braze
Low Pressure Vapor Line Connection (in., OD)	1-1/8 & 1-1/8 Braze	1-1/8 & 1-1/8 Braze	1-1/8 & 1-1/8 Braze
High Pressure Vapor Line Connection (in., OD)	7/8 & 1-1/8 Braze	7/8 & 1-1/8 Braze	1-1/8 & 1-1/8 Braze
Piping for Heat Pump Operation⁷			
Liquid Line Connection (in., OD)	1/2 & 5/8 Braze	5/8 & 5/8 Braze	5/8 & 5/8 Braze
Vapor Line Connection (in., OD)	1-1/8 & 1-1/8 Braze	1-1/8 & 1-1/8 Braze	1-1/8 & 1-1/8 Braze

¹Nominal capacity applied with non-ducted indoor units, and is rated 0 ft. above sea level with 25 ft. of refrigerant line per indoor unit and a 0 ft. level difference between outdoor and indoor units. All capacities are net with a Combination Ratio between 95–105%.

Nominal cooling capacity rating obtained with air entering the indoor unit at 80°F dry bulb (DB) and 67°F wet bulb (WB) and outdoor ambient conditions of 95°F dry bulb (DB) and 75°F wet bulb (WB).

Nominal heating capacity rating obtained with air entering the indoor unit at 70°F dry bulb (DB) and 59°F wet bulb (WB) and outdoor ambient conditions of 47°F dry bulb (DB) and 43°F wet bulb (WB).

²Rated capacity is certified under AHRI Standard 1230. See www.ahrinet.org for information.

³The System Combination Ratio must be between 50–130%.

⁴Sound pressure levels are tested in an anechoic chamber under ISO Standard 3745.

⁵Communication cable between Master ODU to Slave ODU(s), and Master ODU to IDUs / HRUs to be 18 AWG, 2-conductor, twisted, stranded, shielded. Ensure the communication cable shield is properly grounded to the Master ODU chassis only. ⚠ Do not ground the ODU to IDUs / HRUs communication cable at any other point. Wiring must comply with all applicable local and national codes.

⁶Power wiring is field provided, solid or stranded, and must comply with the applicable local and national codes. See page 15 for detailed electrical data.

⁷LG requires that LATS software be used on all projects to ensure correct line sizing. Designer must verify the shop drawing design against the as built design using LATS. Contractor must also use LG manufactured Y-Branch and Header Kits only.

Table 5: Triple Frame 575V Outdoor Units.

Combination Unit Model Number	ARUM432CTE5 36.0 Ton	ARUM456CTE5 38.0 Ton	ARUM480CTE5 40.0 Ton	ARUM504CTE5 42.0 Ton
Individual Component Model Numbers	ARUM121CTE5 + ARUM121CTE5 ARUM192CTE5	ARUM121CTE5 + ARUM121CTE5 + ARUM216CTE5	ARUM121CTE5 + ARUM144CTE5 + ARUM216CTE5	ARUM121CTE5 + ARUM168CTE5 + ARUM216CTE5
Cooling Performance				
Nominal Cooling Capacity (Btu/h) ¹	430,500	455,700	476,700	504,000
Rated Cooling Capacity (Btu/h) ²	410,000	434,000	454,000	480,000
Heating Performance				
Nominal Heating Capacity (Btu/h) ¹	486,000	513,000	540,000	567,000
Rated Heating Capacity (Btu/h) ²	460,000	488,000	513,000	539,000
Operating Range				
Cooling (°F DB)	5 to 122	5 to 122	5 to 122	5 to 122
Heating (°F WB)	-22 to +61	-22 to +61	-22 to +61	-22 to +61
Synchronous — Cooling Based (°F DB)	14 to 81	14 to 81	14 to 81	14 to 81
Synchronous — Heating Based (°F WB)	14 to 61	14 to 61	14 to 61	14 to 61
Compressor				
Inverter Quantity	HSS DC Scroll x 4	HSS DC Scroll x 4	HSS DC Scroll x 5	HSS DC Scroll x 5
Oil/Type	PVE / FVC68D	PVE / FVC68D	PVE / FVC68D	PVE / FVC68D
Fan (Top Discharge)				
Type	Propeller (BLDC)	Propeller (BLDC)	Propeller (BLDC)	Propeller (BLDC)
Motor Output (kW) x Qty.	0.90x2 + 0.90x2 + 0.90x2	0.90x2 + 0.90x2 + 0.90x2	0.90x2 + 0.90x2 + 0.90x2	0.90x2 + 0.90x2 + 0.90x2
Motor/Drive	Brushless Digitally Controlled / Direct			
Operating Range (RPM)	Cooling	0 - 1,150	0 - 1,150	0 - 1,150
	Heating	80 - 1,150	80 - 1,150	80 - 1,150
Maximum Air Volume (CFM)	33,900	33,900	33,900	33,900
Unit Data				
Refrigerant Type	R410A	R410A	R410A	R410A
Refrigerant Control/Location	EEV / Indoor Unit	EEV / Indoor Unit	EEV / Indoor Unit	EEV / Indoor Unit
Factory Charge lbs. of R410A	23.2 + 23.2 + 30.9	23.2 + 23.2 + 37.5	23.2 + 26.5 + 37.5	23.2 + 26.5 + 37.5
Max. No. Indoor Units/System ³	61	64	64	64
Sound Pressure dB(A) ⁴	66.0	66.0	67.0	67.0
Net Unit Weight (lbs.)	507 + 507 + 659	507 + 507 + 666	507 + 639 + 666	507 + 639 + 666
Shipping Weight (lbs.)	534 + 534 + 688	534 + 534 + 694	534 + 666 + 694	534 + 666 + 694
Communication Cables ^{5,6}	2 x 18	2 x 18	2 x 18	2 x 18
Heat Exchanger				
Material and Fin Coating	Copper Tube / Aluminum Fin and Black Coated Fin™ / Hydrophilic			
Rows/Fins per inch	2/17 x 2 + 3/17	2 / 17 x 2 + 3 / 17	2 / 17 + 3 / 17 x 2	2 / 17 + 3 / 17 x 2
Piping for Heat Recovery Operation⁷				
Liquid Line Connection (in., OD)	1/2 & 1/2 & 5/8 Braze	1/2 & 1/2 & 5/8 Braze	1/2 & 1/2 & 5/8 Braze	1/2 & 5/8 & 5/8 Braze
Low Pressure Vapor Line Conn. (in., OD)	1-1/8 & 1-1/8 & 1-1/8 Braze	1-1/8 & 1-1/8 & 1-1/8 Braze	1-1/8 & 1-1/8 & 1-1/8 Braze	1-1/8 & 1-1/8 & 1-1/8 Braze
High Pressure Vapor Line Conn. (in., OD)	7/8 & 7/8 & 1-1/8 Braze	7/8 & 7/8 & 1-1/8 Braze	7/8 & 7/8 & 1-1/8 Braze	7/8 & 7/8 & 1-1/8 Braze
Piping for Heat Pump Operation⁷				
Liquid Line Connection (in., OD)	1/2 & 1/2 & 5/8 Braze	1/2 & 1/2 & 5/8 Braze	1/2 & 1/2 & 5/8 Braze	1/2 & 5/8 & 5/8 Braze
Vapor Line Connection (in., OD)	1-1/8 & 1-1/8 & 1-1/8 Braze	1-1/8 & 1-1/8 & 1-1/8 Braze	1-1/8 & 1-1/8 & 1-1/8 Braze	1-1/8 & 1-1/8 & 1-1/8 Braze

¹Nominal capacity applied with non-ducted indoor units, and is rated 0 ft. above sea level with 25 ft. of refrigerant line per indoor unit and a 0 ft. level difference between outdoor and indoor units. All capacities are net with a Combination Ratio between 95–105%.

Nominal cooling capacity rating obtained with air entering the indoor unit at 80°F dry bulb (DB) and 67°F wet bulb (WB) and outdoor ambient conditions of 95°F dry bulb (DB) and 75°F wet bulb (WB).

Nominal heating capacity rating obtained with air entering the indoor unit at 70°F dry bulb (DB) and 59°F wet bulb (WB) and outdoor ambient conditions of 47°F dry bulb (DB) and 43°F wet bulb (WB).

²Rated capacity is certified under AHRI Standard 1230. See www.ahrinet.org for information.

³The System Combination Ratio must be between 50–130%.

⁴Sound pressure levels are tested in an anechoic chamber under ISO Standard 3745.

⁵Communication cable between Master ODU to Slave ODU(s), and Master ODU to IDUs / HRUs to be 18 AWG, 2-conductor, twisted, stranded, shielded. Ensure the communication cable shield is properly grounded to the Master ODU chassis only. Do not ground the ODU to IDUs / HRUs communication cable at any other point. Wiring must comply with all applicable local and national codes.

⁶Power wiring is field provided, solid or stranded, and must comply with the applicable local and national codes. See page 15 for detailed electrical data.

⁷LG requires that LATS software be used on all projects to ensure correct line sizing. Designer must verify the shop drawing design against the as built design using LATS. Contractor must also use LG manufactured Y-Branch and Header Kits only.

ELECTRICAL DATA



575V Outdoor Unit Electrical Data

Table 6: 575V, 60Hz, 3-Phase Outdoor Units.

Nom. Tons	Unit Model Nos.	Comp. Qty.	Compressor (Comp.)						Fan Qty.	Condenser Fan Motor(s)			MCA			MOP			RFA / MOCP								
			Motor Amps							Amps			Frame			Frame			Frame								
			Motor RLA (Ea.)							FLA (Ea.)			1			2			3								
			Frame							Frame			1			2			3								
			1		2		3			1			2			3			1			2			3		
			Comp. A	Comp. B	Comp. A	Comp. B	Comp. A	Comp. B		1	2	3	1	2	3	1	2	3	1	2	3	1	2	3			
6.0	ARUM072CTE5	1	7.8	-	-	-	-	-	2	5.0	-	-	14.8	-	-	22.6	-	-	20	-	-						
8.0	ARUM096CTE5	1	9.1	-	-	-	-	-	2	5.0	-	-	16.4	-	-	25.5	-	-	25	-	-						
10.0	ARUM121CTE5	1	10.7	-	-	-	-	-	2	5.0	-	-	18.4	-	-	29.1	-	-	25	-	-						
12.0	ARUM144CTE5	2	10.3	8.5	-	-	-	-	2	5.0	-	-	26.4	-	-	36.7	-	-	35	-	-						
14.0	ARUM168CTE5	2	11.4	9.2	-	-	-	-	2	5.0	-	-	28.5	-	-	39.9	-	-	35	-	-						
16.0	ARUM192CTE5	2	14.8	12.2	-	-	-	-	2	5.0	-	-	35.7	-	-	50.5	-	-	50	-	-						
18.0	ARUM216CTE5	2	15.5	13.9	-	-	-	-	2	5.0	-	-	38.3	-	-	53.8	-	-	50	-	-						
20.0	ARUM241CTE5	2	16.9	15.3	-	-	-	-	2	5.0	-	-	41.4	-	-	58.3	-	-	50	-	-						
22.0	ARUM264CTE5	3	11.4	9.2	9.1	-	-	-	4	5.0	5.0	-	28.5	16.4	-	39.9	25.5	-	35	25	-						
24.0	ARUM288CTE5	3	14.8	12.2	9.1	-	-	-	4	5.0	5.0	-	35.7	16.4	-	50.5	25.5	-	50	25	-						
26.0	ARUM312CTE5	3	15.5	13.9	9.1	-	-	-	4	5.0	5.0	-	38.3	16.4	-	53.8	25.5	-	50	25	-						
28.0	ARUM336CTE5	3	15.5	13.9	10.7	-	-	-	4	5.0	5.0	-	38.3	18.4	-	53.8	29.1	-	50	25	-						
30.0	ARUM360CTE5	4	15.5	13.9	10.3	8.5	-	-	4	5.0	5.0	-	38.3	26.4	-	53.8	36.7	-	50	35	-						
32.0	ARUM384CTE5	4	15.5	13.9	11.4	9.2	-	-	4	5.0	5.0	-	38.3	28.5	-	53.8	39.9	-	50	35	-						
34.0	ARUM408CTE5	4	15.5	13.9	14.8	12.2	-	-	4	5.0	5.0	-	38.3	35.7	-	53.8	50.5	-	50	50	-						
36.0	ARUM432CTE5	4	14.8	12.2	10.7	-	10.7	-	6	5.0	5.0	5.0	35.7	18.4	18.4	50.5	29.1	29.1	50	25	25						
38.0	ARUM456CTE5	4	15.5	13.9	10.7	-	10.7	-	6	5.0	5.0	5.0	38.3	18.4	18.4	53.8	29.1	29.1	50	25	25						
40.0	ARUM480CTE5	5	15.5	13.9	10.3	8.5	10.7	-	6	5.0	5.0	5.0	38.3	26.4	18.4	53.8	36.7	29.1	50	35	25						
42.0	ARUM504CTE5	5	15.5	13.9	11.4	9.2	10.7	-	6	5.0	5.0	5.0	38.3	28.5	18.4	53.8	39.9	29.1	50	35	25						

For component model nos. see the specification tables on p. 11-15.

Voltage tolerance is +/- 10%.

Maximum allowable voltage unbalance is 2%.

MCA = Minimum Circuit Ampacity.

Maximum Overcurrent Protection (MOCP) is calculated as follows: (Largest motor FLA x 2.25) + (Sum of other motor FLA) rounded down to the nearest standard fuse size.

RFA = Recommended Fuse Amps.

*SCCR rating: 5kA RMS Symmetrical.

Table 7: Outdoor Unit Connection Limitations.

Outdoor Unit Model No.	Nominal Cooling (Btu/h)	Indoor Units		
		Sum of Indoor Unit Nominal Cooling Capacities (Btu/h)		
		Max. Qty.	Min. Capacity (Btu/h) (50%)*	Max. Capacity (Btu/h) (130%)
575V				
ARUM072CTE5	72,000	13	36,000	93,600
ARUM096CTE5	96,000	16	48,000	124,800
ARUM121CTE5	119,700	20	60,000	156,000
ARUM144CTE5	144,000	24	72,000	187,200
ARUM168CTE5	168,000	29	84,000	218,400
ARUM192CTE5	192,000	32	96,000	249,600
ARUM216CTE5	216,000	35	108,000	280,800
ARUM241CTE5	233,100	39	120,000	312,000
ARUM264CTE5	264,000	42	132,000	343,200
ARUM288CTE5	288,000	45	144,000	374,400
ARUM312CTE5	312,000	52	156,000	405,600
ARUM336CTE5	336,000	55	168,000	436,800
ARUM360CTE5	360,000	58	180,000	468,000
ARUM384CTE5	384,000	61	192,000	499,200
ARUM408CTE5	408,000	64	204,000	530,400
ARUM432CTE5	430,500	64	216,000	561,600
ARUM456CTE5	455,700	64	228,000	592,800
ARUM480CTE5	476,700	64	240,000	624,000
ARUM504CTE5	504,000	64	252,000	655,200

DIMENSIONS

MULTI V™ 5

ARUM072CTE5, 096CTE5, 121CTE5, 144CTE5,
168CTE5, 192CTE5, 216CTE5, 241CTE5

Note: Please refer to multi-frame placement information and piping rules in the Multi V 5 Engineering Manual and the Multi V 5 Installation Manual. Minimum spacing between frames is 1 inch.

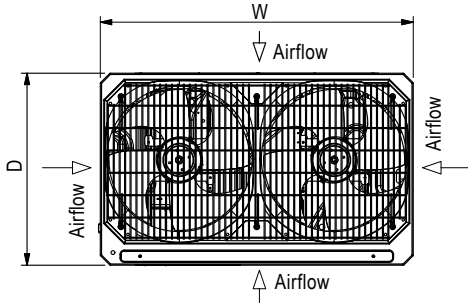

Top View

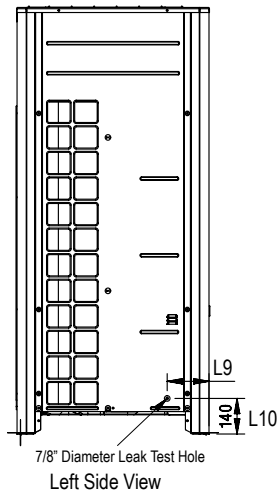
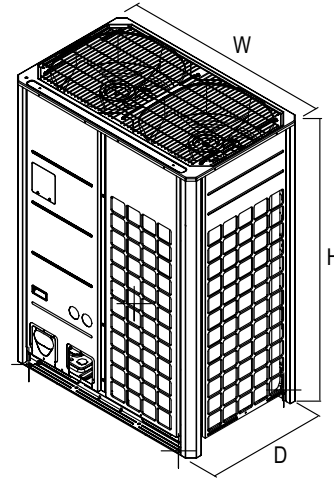

Left Side View

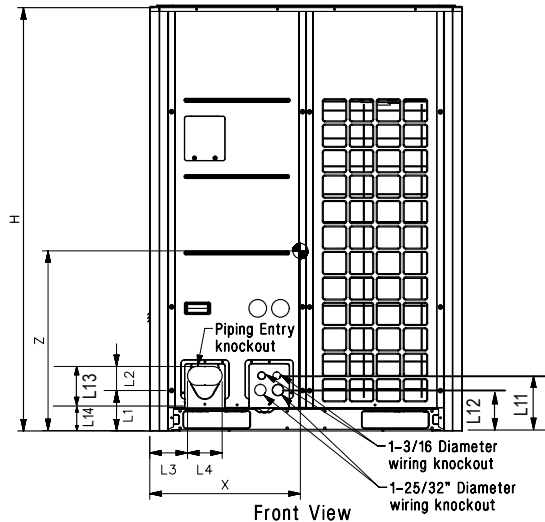

Front View

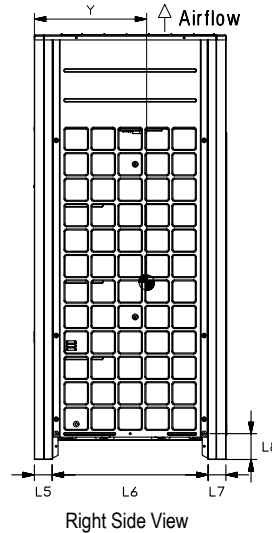

Right Side View

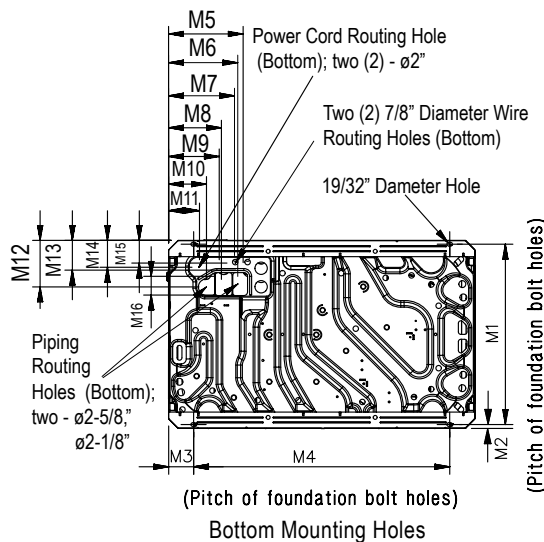

Bottom Mounting Holes

W	48-13/16"
H	66-17/32"
D	29-29/32"
L1	6-5/16"
L2	3-3/4"
L3	5-29/32"
L4	5-13/32"
L5	2-25/32"
L6	24-9/32"
L7	2-25/32"
L8	4-1/32"
L9	6-1/2"
L10	5-9/16"
L11	8-5/8"
L12	6-7/16"
L13	9-15/16"
L14	3-5/8"

Center of Gravity

X	23-7/32"
Y	15-5/8"
Z	25-9/16"

M1	28-25/32"
M2	5/8"
M3	3-15/16"
M4	40-15/16"
M5	11-15/16"
M6	11-1/16"
M7	10-1/2"
M8	8-7/16"
M9	8-1/8"
M10	6-1/16"
M11	4-15/16"
M12	7-1/2"
M13	4-13/16"
M14	4-5/16"
M15	3-5/8"
M16	3"

All dimensions have a tolerance of ± 0.25 in. [Unit: inch]

= Center of Gravity

ARUM264CTE5, 288CTE5, 312CTE5, 336CTE5,
360CTE5, 384CTE5, 408CTE5

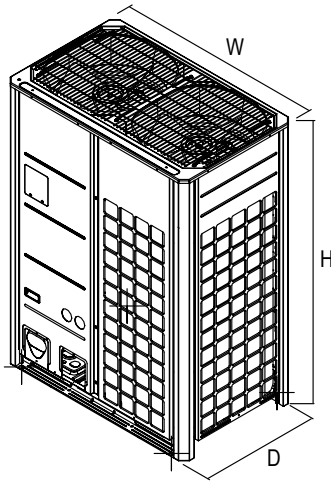

Typical Dual Frame Configuration

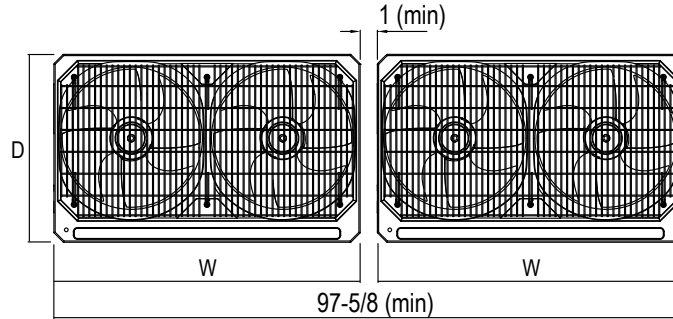

Note: Please refer to multi-frame placement information and piping rules in the Multi V 5 Engineering Manual and the Multi V 5 Installation Manual. Minimum spacing between frames is 1 inch.

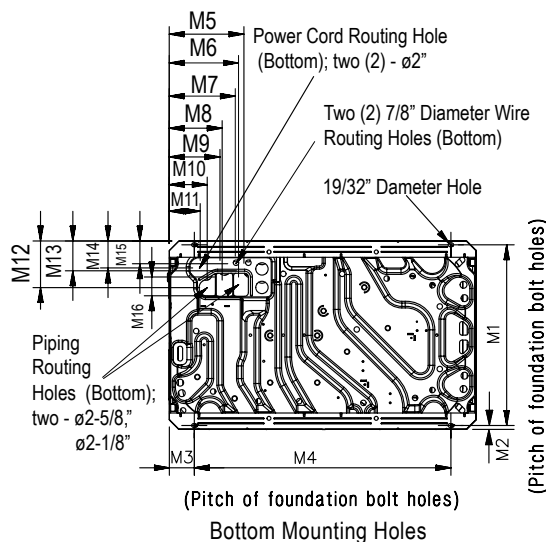
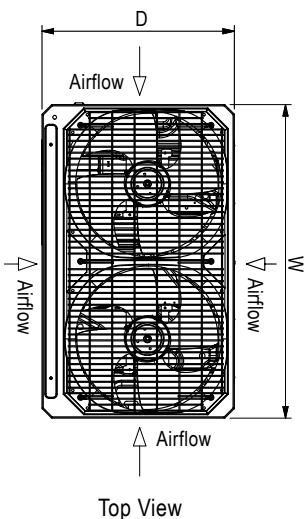
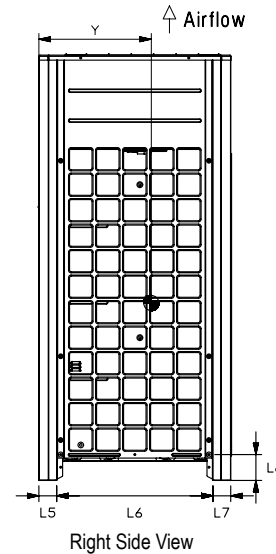
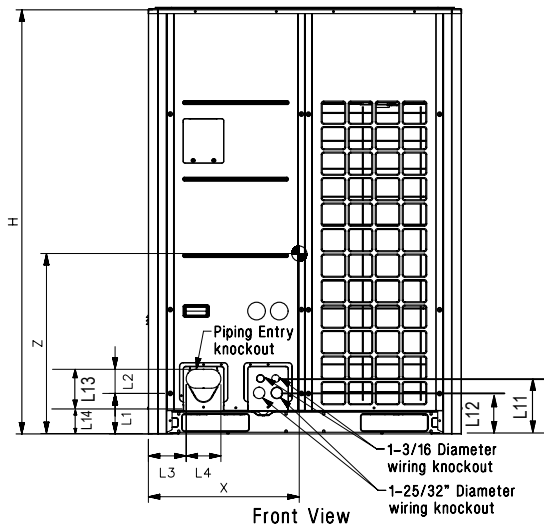
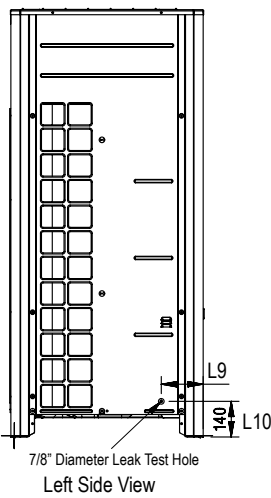

M1	28-25/32"
M2	5/8"
M3	3-15/16"
M4	40-15/16"
M5	11-15/16"
M6	11-1/16"
M7	10-1/2"
M8	8-7/16"
M9	8-1/8"
M10	6-1/16"
M11	4-15/16"
M12	7-1/2"
M13	4-13/16"
M14	4-5/16"
M15	3-5/8"
M16	3"

W	48-13/16"
H	66-17/32"
D	29-29/32"
L1	6-5/16"
L2	3-3/4"
L3	5-29/32"
L4	5-13/32"
L5	2-25/32"
L6	24-9/32"
L7	2-25/32"
L8	4-1/32"
L9	6-1/2"
L10	5-9/16"
L11	8-5/8"
L12	6-7/16"
L13	9-15/16"
L14	3-5/8"

Center of Gravity

X	23-7/32"
Y	15-5/8"
Z	25-9/16"

All dimensions have a tolerance of ± 0.25 in.
[Unit: inch]

= Center of Gravity

DIMENSIONS

MULTI V 5

ARUM432CTE5, 456CTE5, 480CTE5, 504CTE5

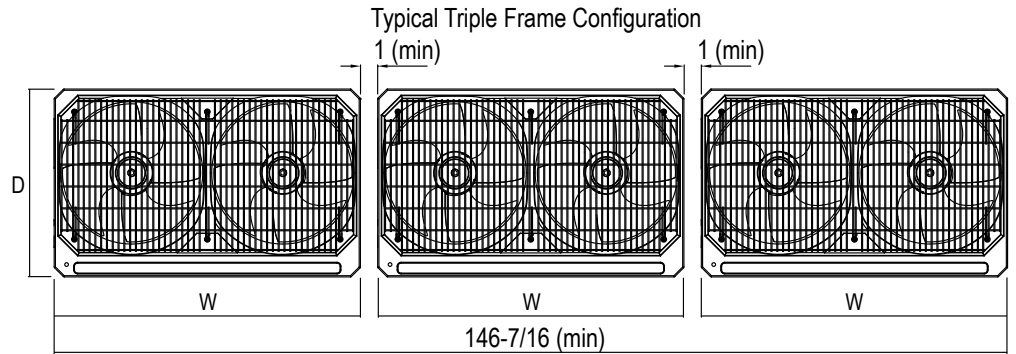
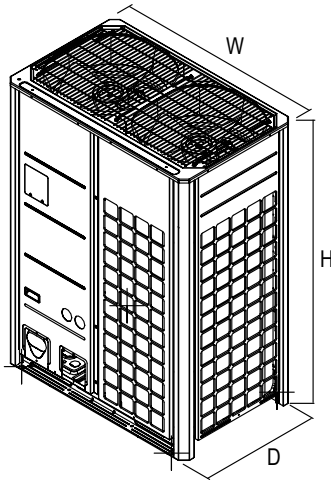

Note: Please refer to multi-frame placement information and piping rules in the Multi V 5 Engineering Manual and the Multi V 5 Installation Manual. Minimum spacing between frames is 1 inch.

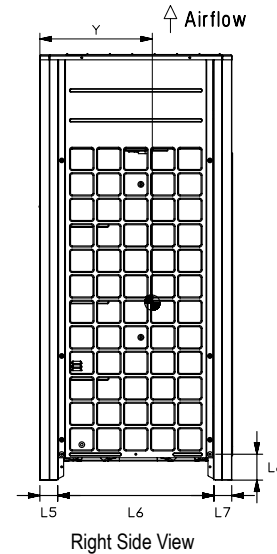
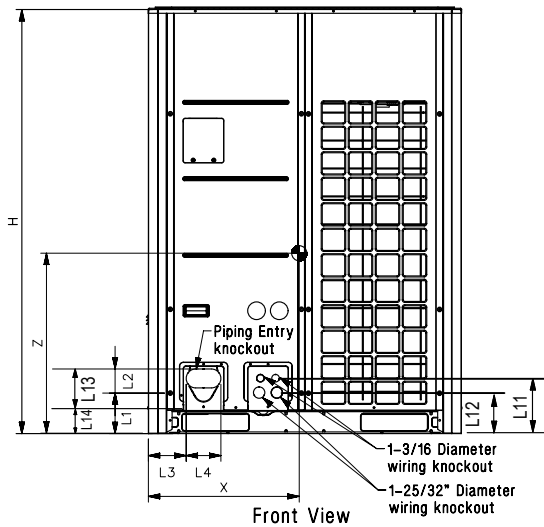
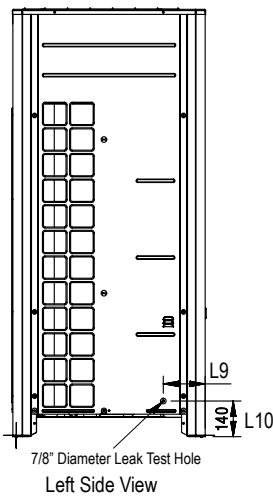

W	48-13/16"
H	66-17/32"
D	29-29/32"
L1	6-5/16"
L2	3-3/4"
L3	5-29/32"
L4	5-13/32"
L5	2-25/32"
L6	24-9/32"
L7	2-25/32"
L8	4-1/32"
L9	6-1/2"
L10	5-9/16"
L11	8-5/8"
L12	6-7/16"
L13	9-15/16"
L14	3-5/8"

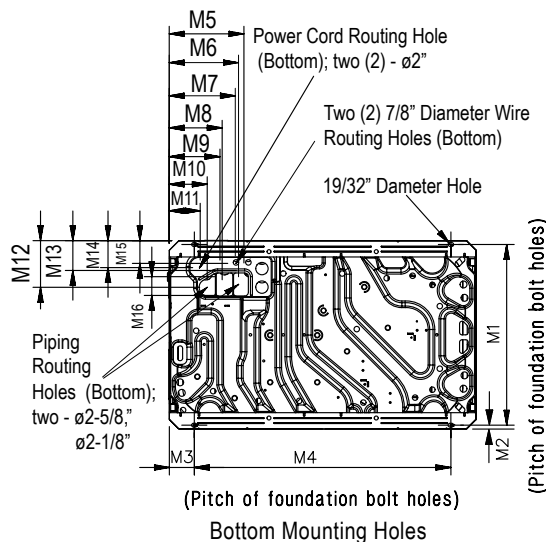
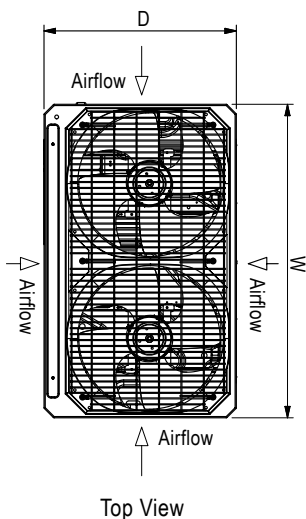

M1	28-25/32"
M2	5/8"
M3	3-15/16"
M4	40-15/16"
M5	11-15/16"
M6	11-1/16"
M7	10-1/2"
M8	8-7/16"
M9	8-1/8"
M10	6-1/16"
M11	4-15/16"
M12	7-1/2"
M13	4-13/16"
M14	4-5/16"
M15	3-5/8"
M16	3"

Center of Gravity

X	23-7/32"
Y	15-5/8"
Z	25-9/16"

All dimensions have a tolerance of ± 0.25 in.
[Unit: inch]

= Center of Gravity

5. Wiring Diagrams

5.1 Heat Recovery & Heat Pump Model

5.1.1 6~10 Ton ARUM072CTE5 / ARUM096CTE5 / ARUM121CTE5

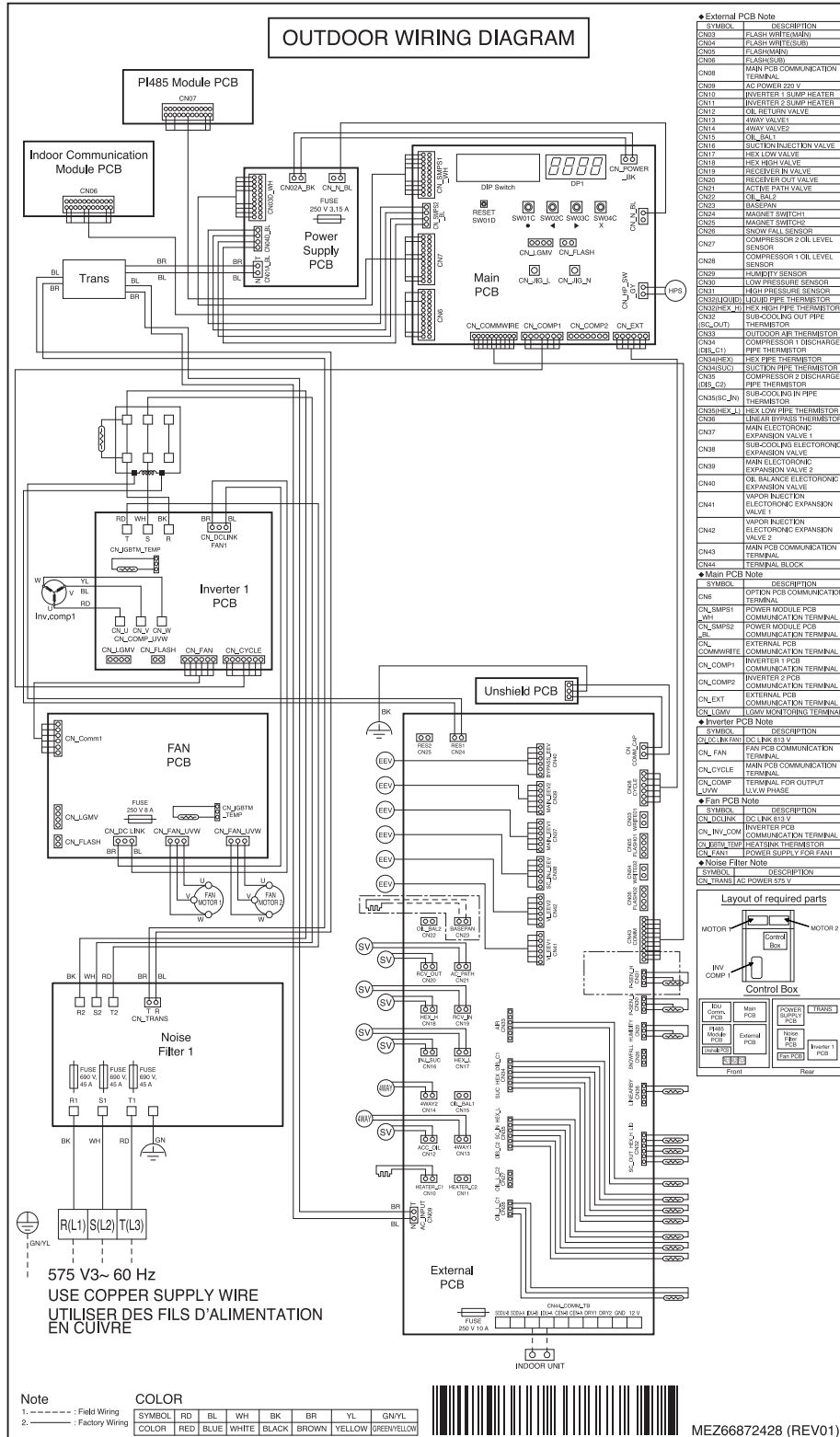

5.1.2 12~14 Ton ARUM144CTE5 / ARUM168CTE5

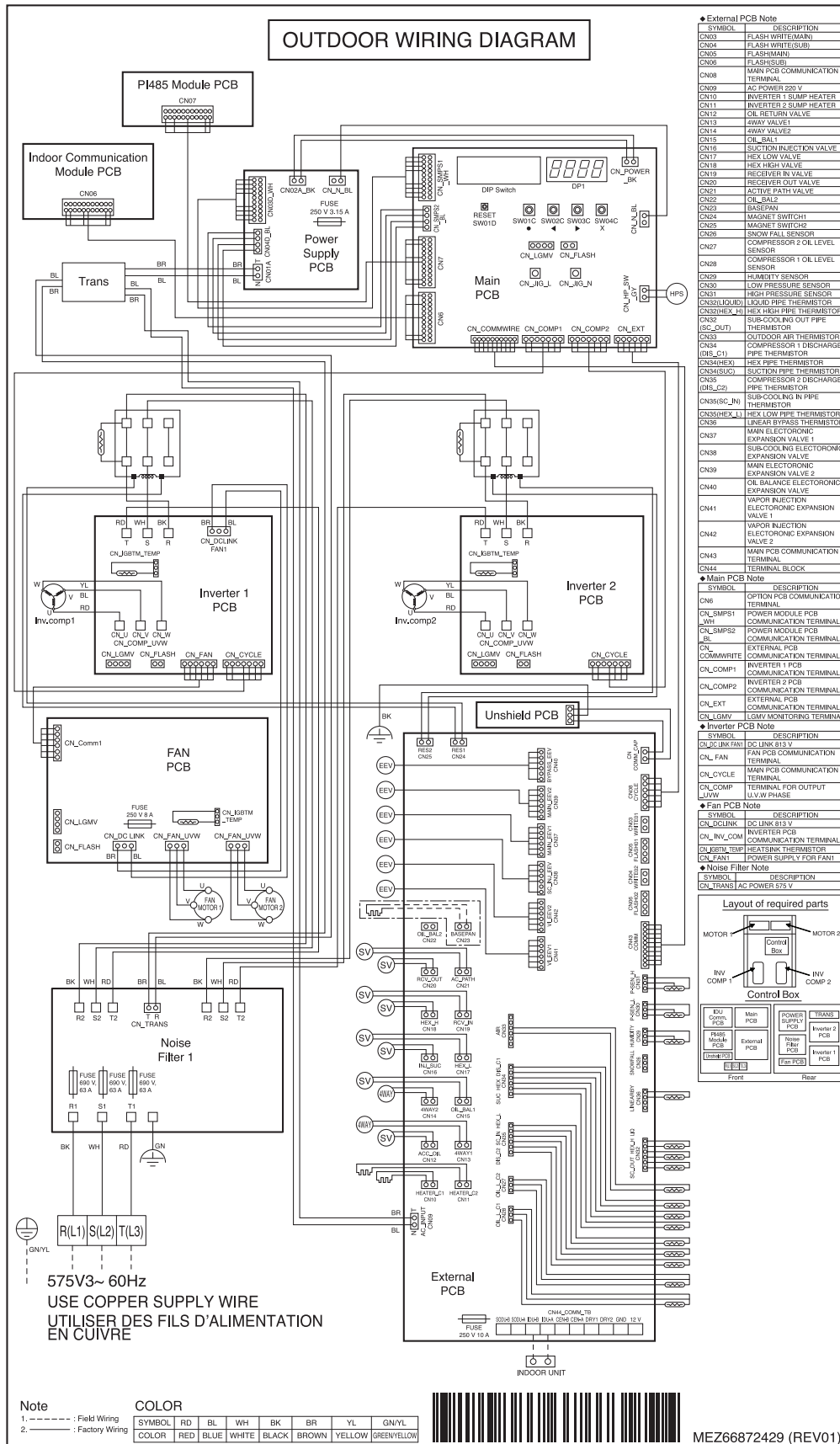

5.1.3 16~20 Ton ARUM192CTE5 / ARUM216CTE5 / ARUM241CTE5

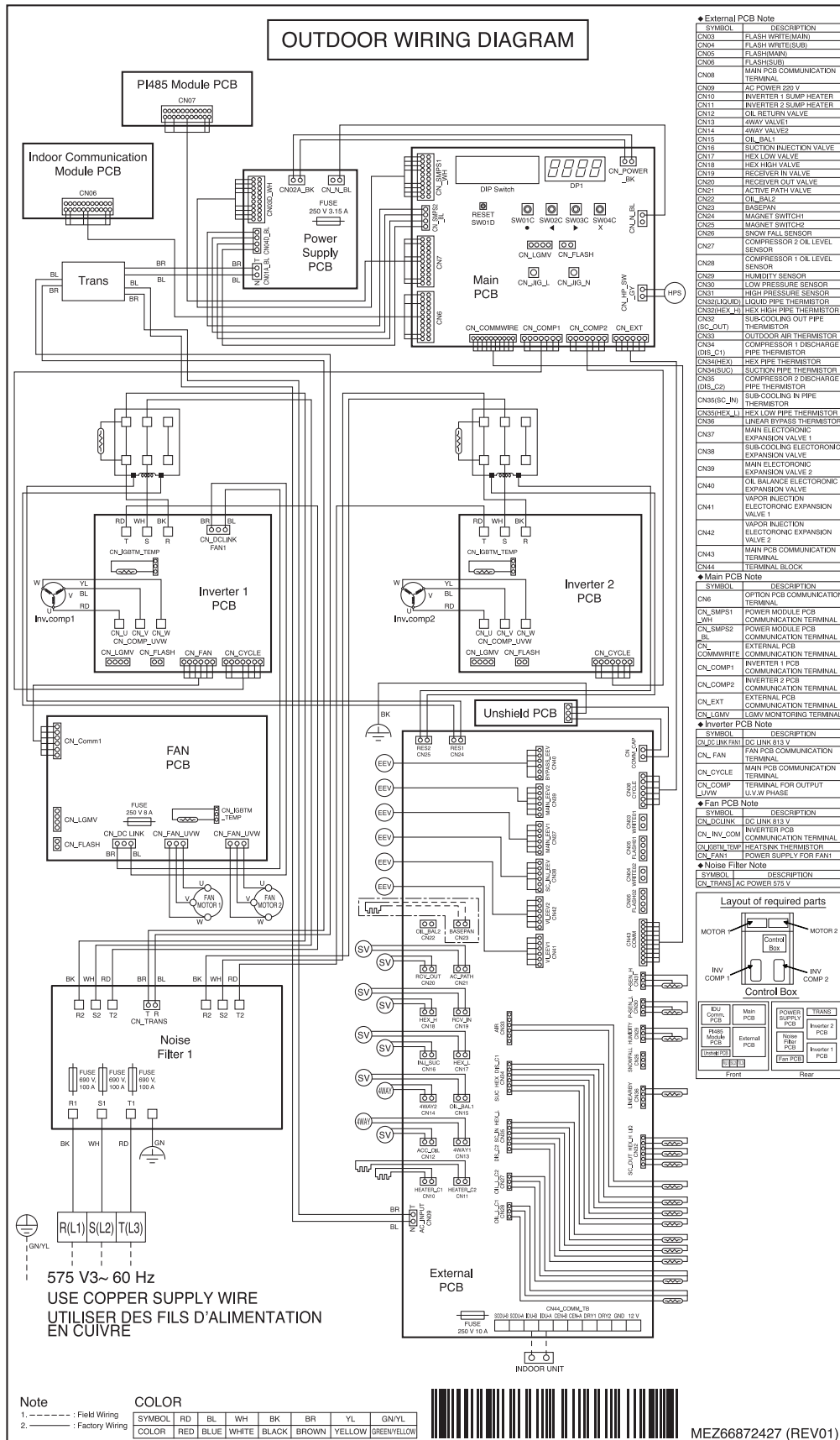

REFRIGERANT FLOW DIAGRAMS

MULTI V™ 5

ARUM072CTE5, 096CTE5, 121CTE5

Heat Recovery Operation — Cooling Mode

MULTI V 5 Outdoor Unit Engineering Manual

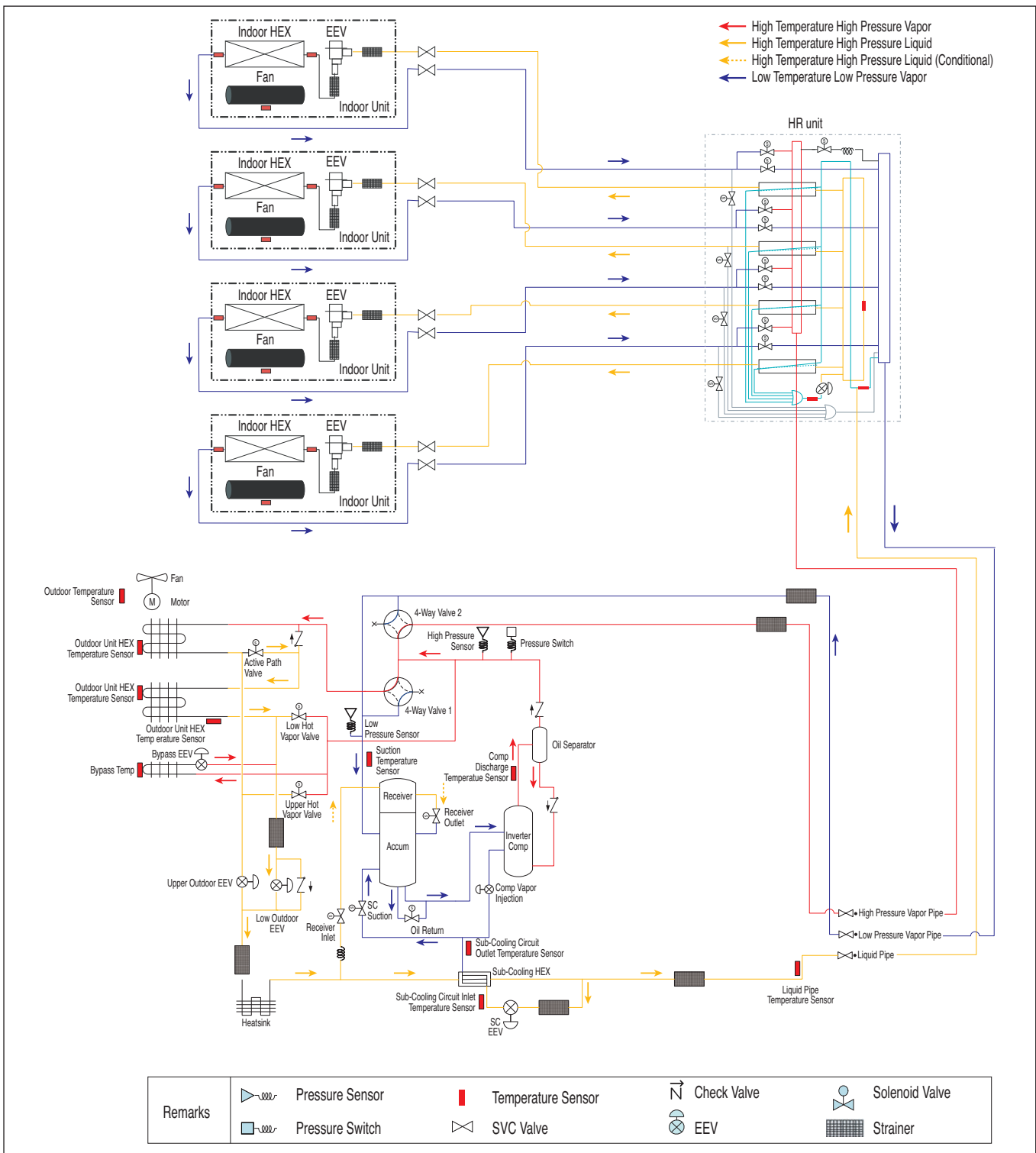

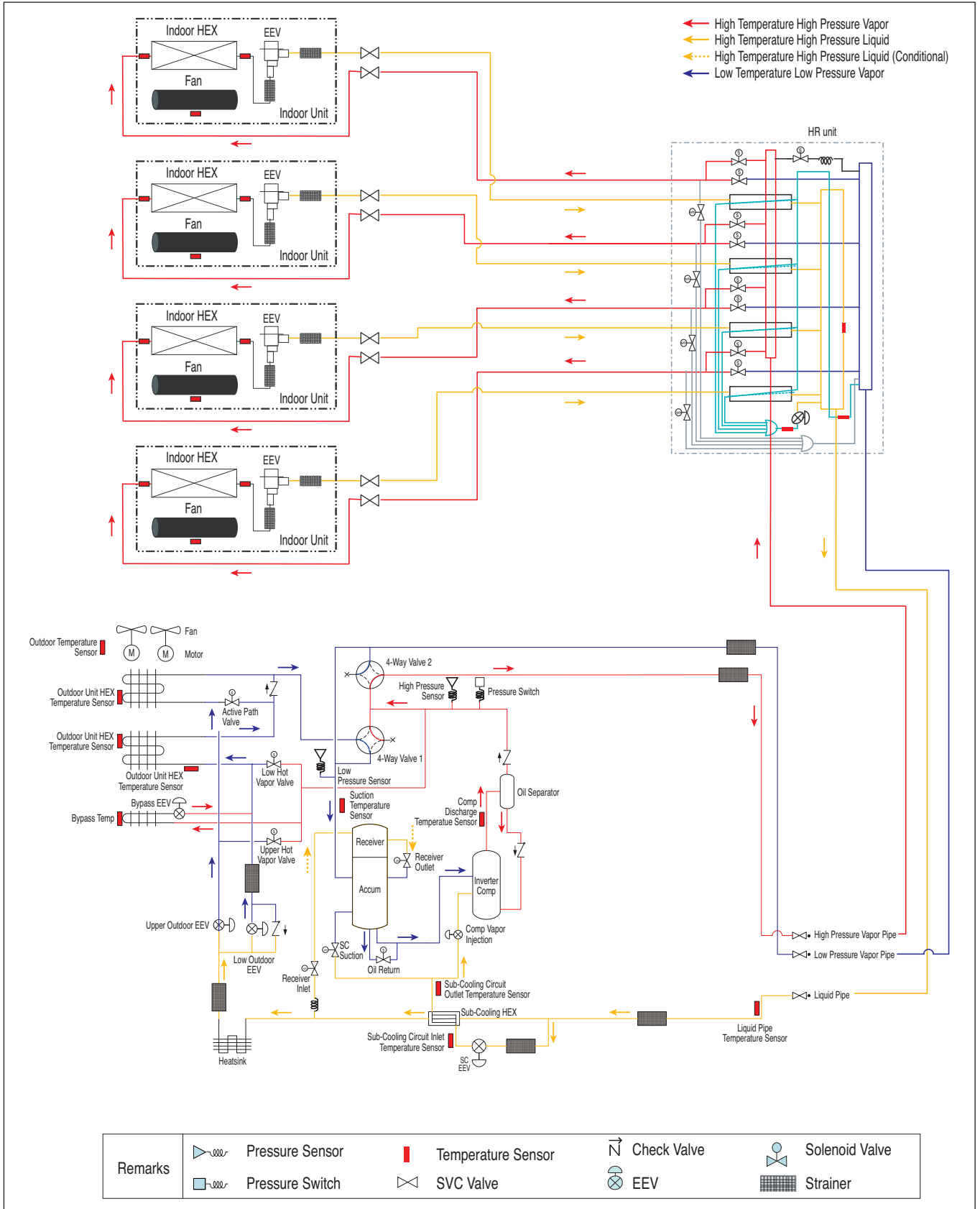

Outdoor Unit Product Data

REFRIGERANT FLOW DIAGRAMS

MULTI V™ 5

ARUM072CTE5, 096CTE5, 121CTE5

Heat Recovery Operation — Oil Return and Defrost

MULTI V 5 Outdoor Unit Engineering Manual

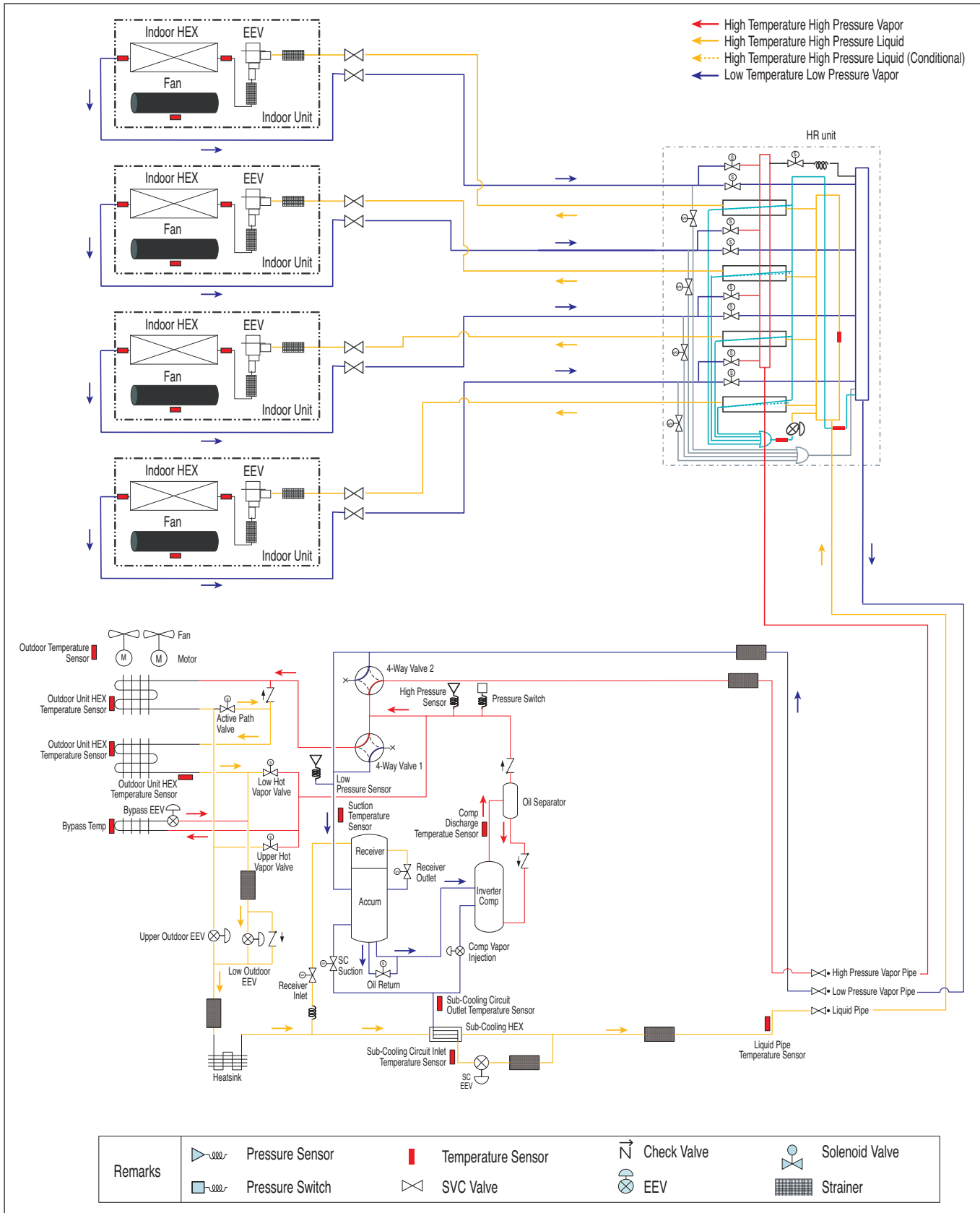

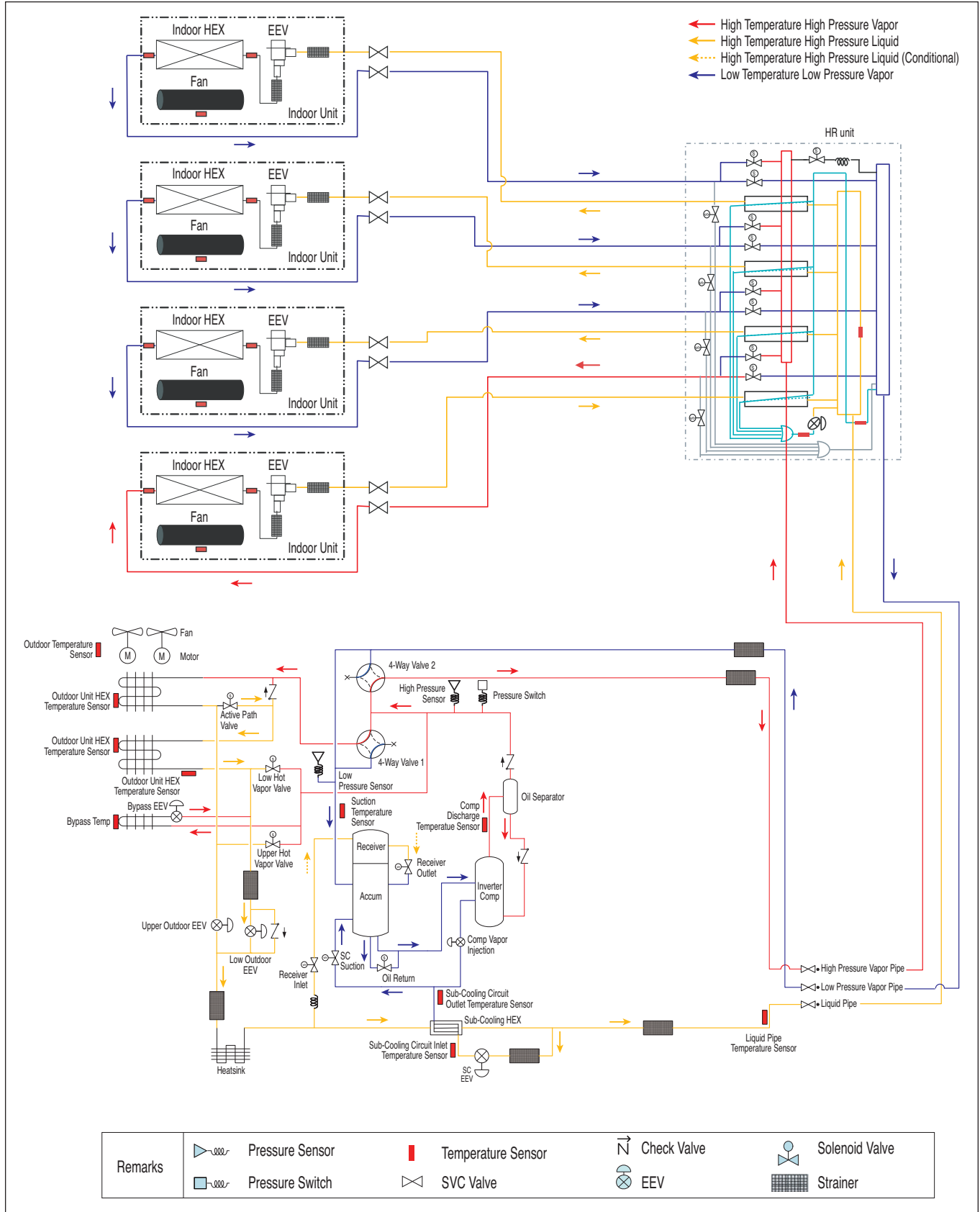

REFRIGERANT FLOW DIAGRAMS

MULTI V™ 5

ARUM072CTE5, 096CTE5, 121CTE5

Heat Recovery Operation — Heating-based Simul. Operation

MULTI V 5 Outdoor Unit Engineering Manual

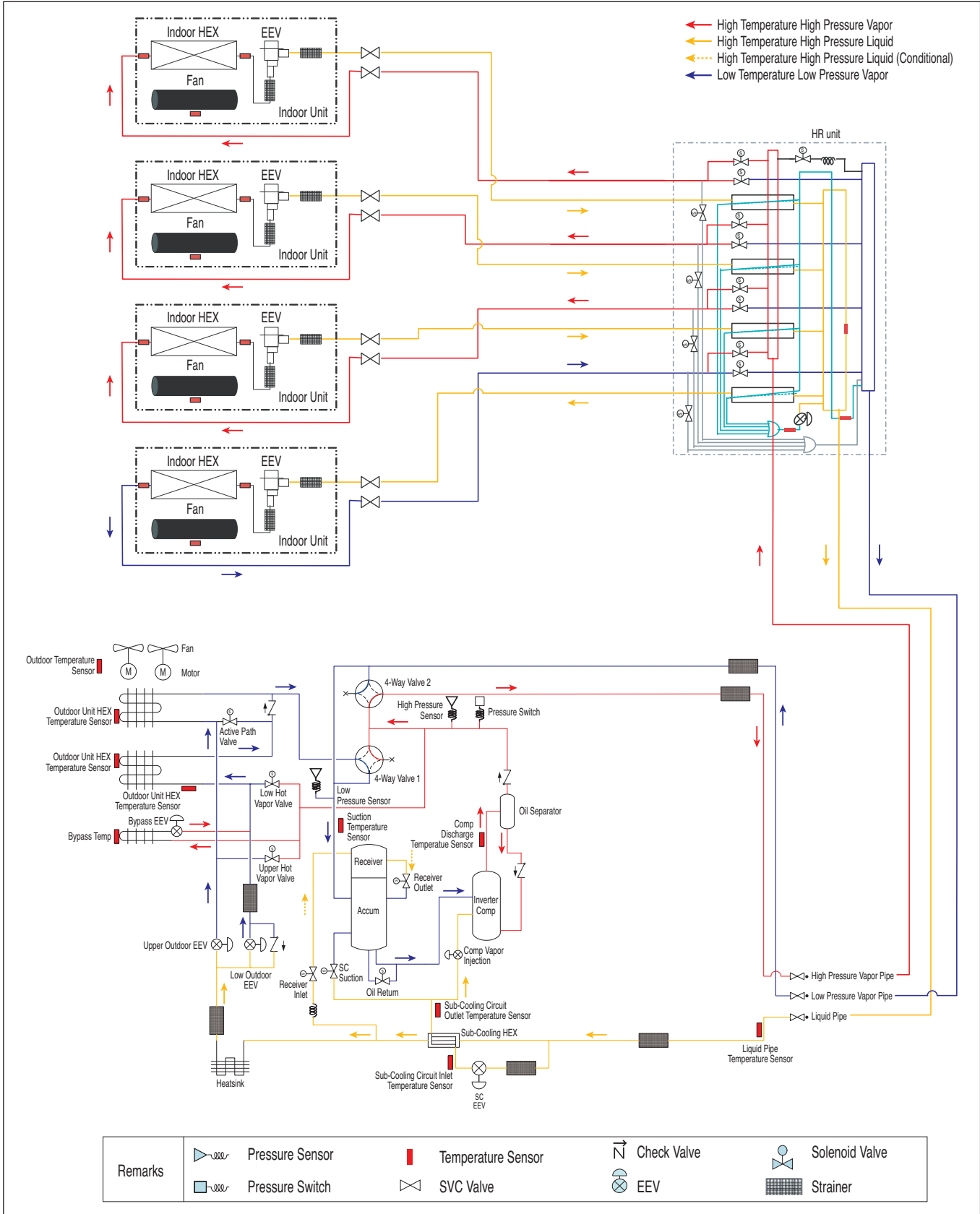

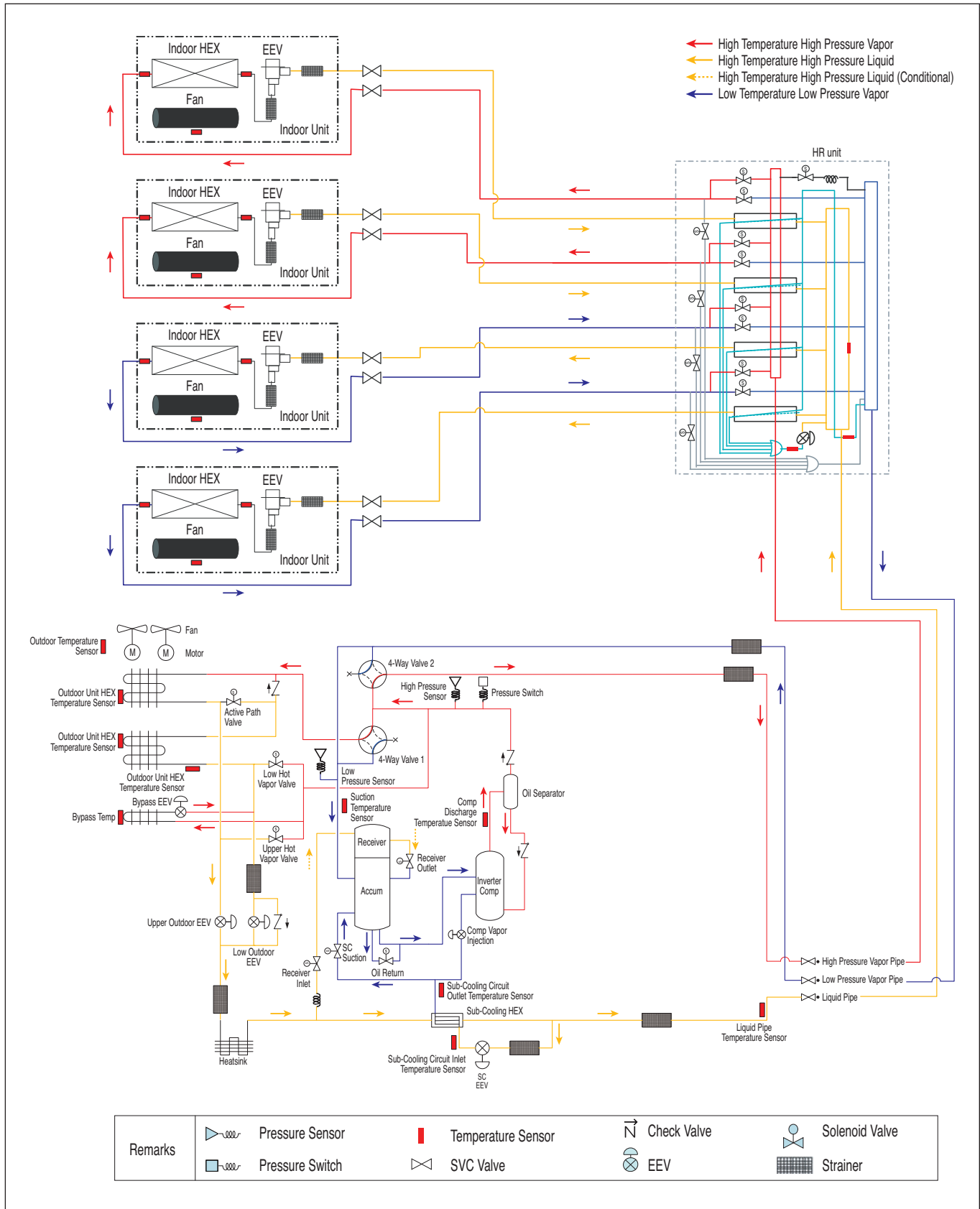

REFRIGERANT FLOW DIAGRAMS

MULTI V™ 5

ARUM072CTE5, 096CTE5, 121CTE5

Heat Recovery Operation — Upper Heat Exchanger Defrost Operation

MULTI V 5 Outdoor Unit Engineering Manual

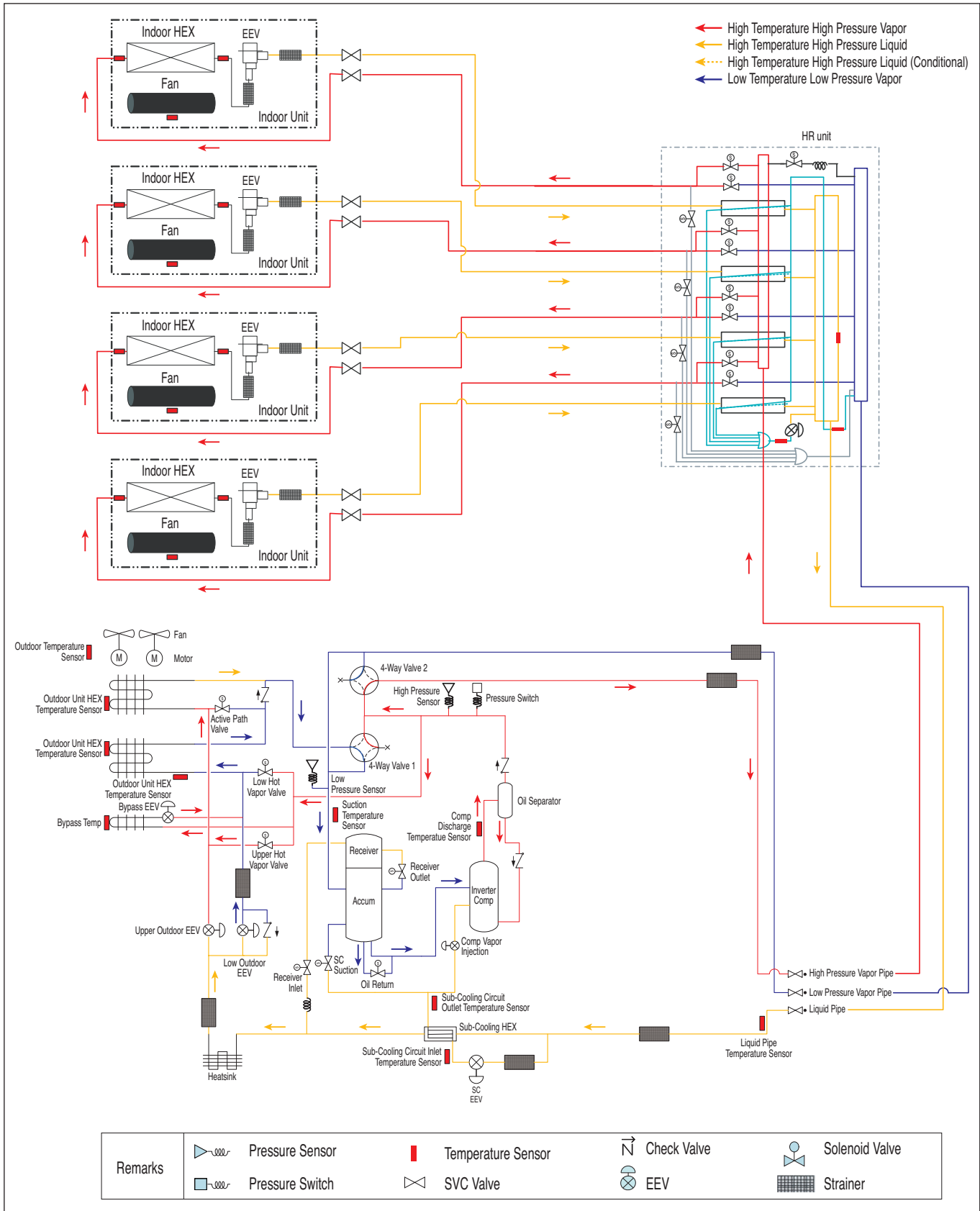

Heat Recovery Operation — Low Heat Exchanger Defrost Operation

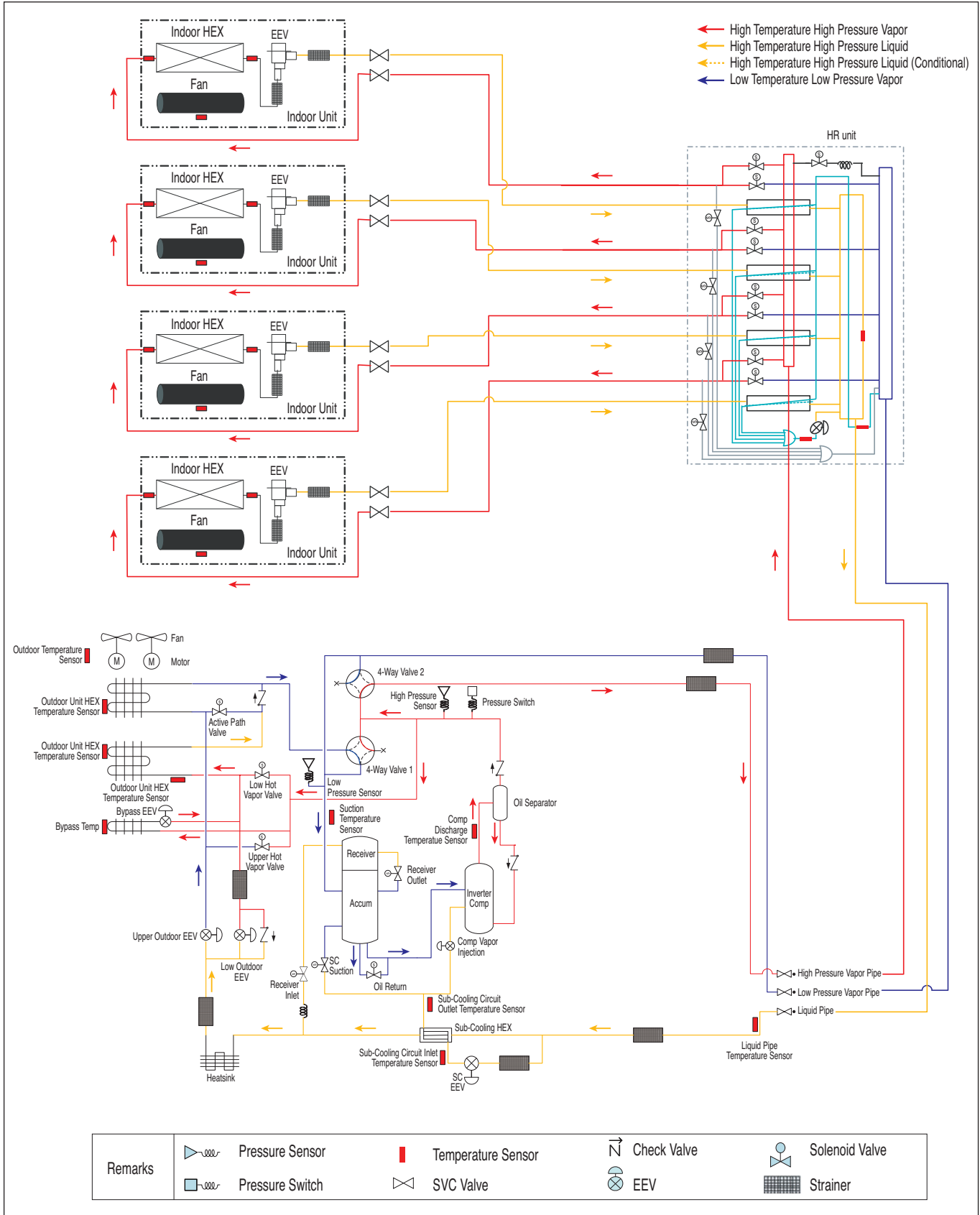

Outdoor Unit Product Data

REFRIGERANT FLOW DIAGRAMS

MULTI V™ 5

ARUM072CTE5, 096CTE5, 121CTE5

Heat Pump Operation — Cooling Mode

MULTI V 5 Outdoor Unit Engineering Manual

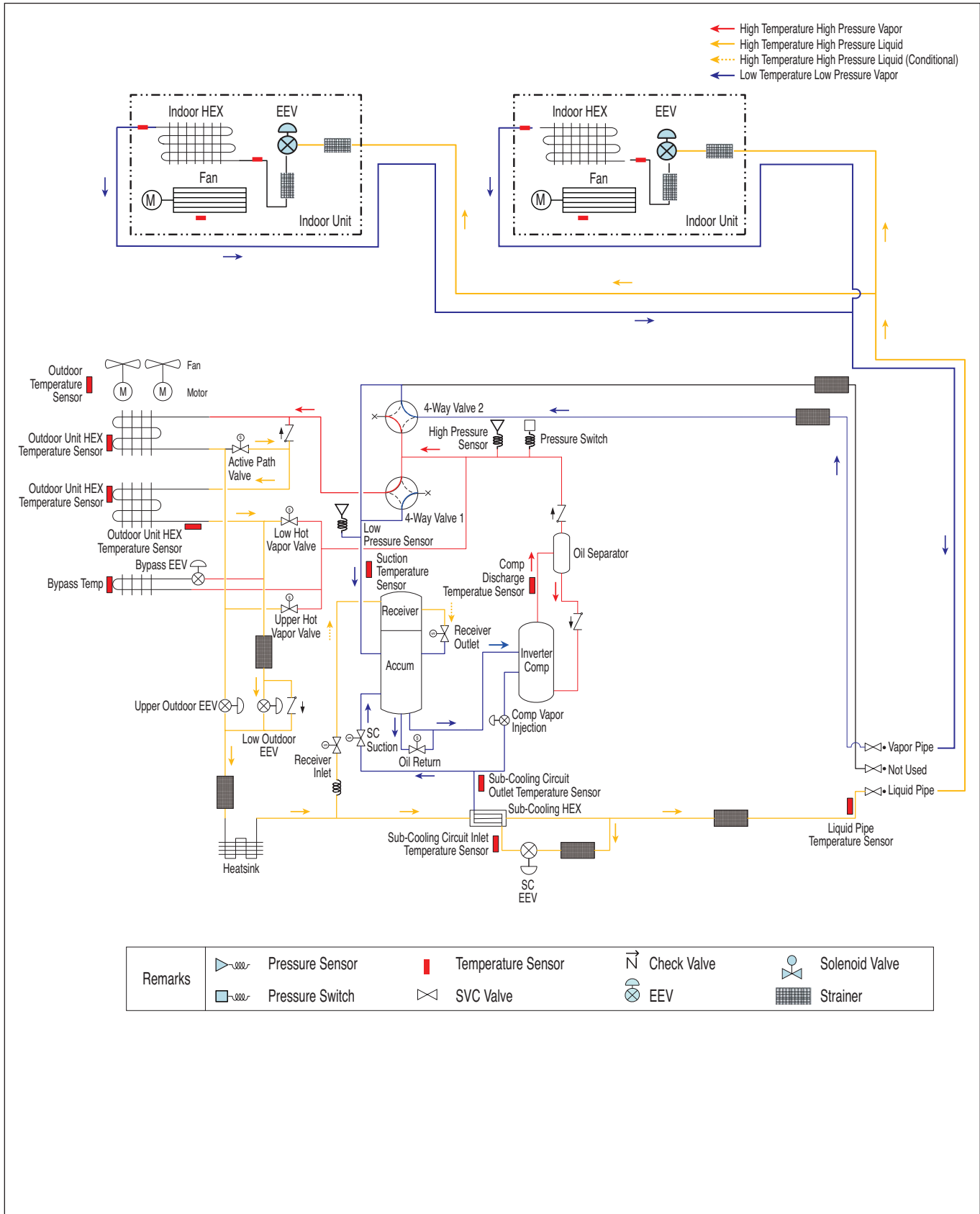

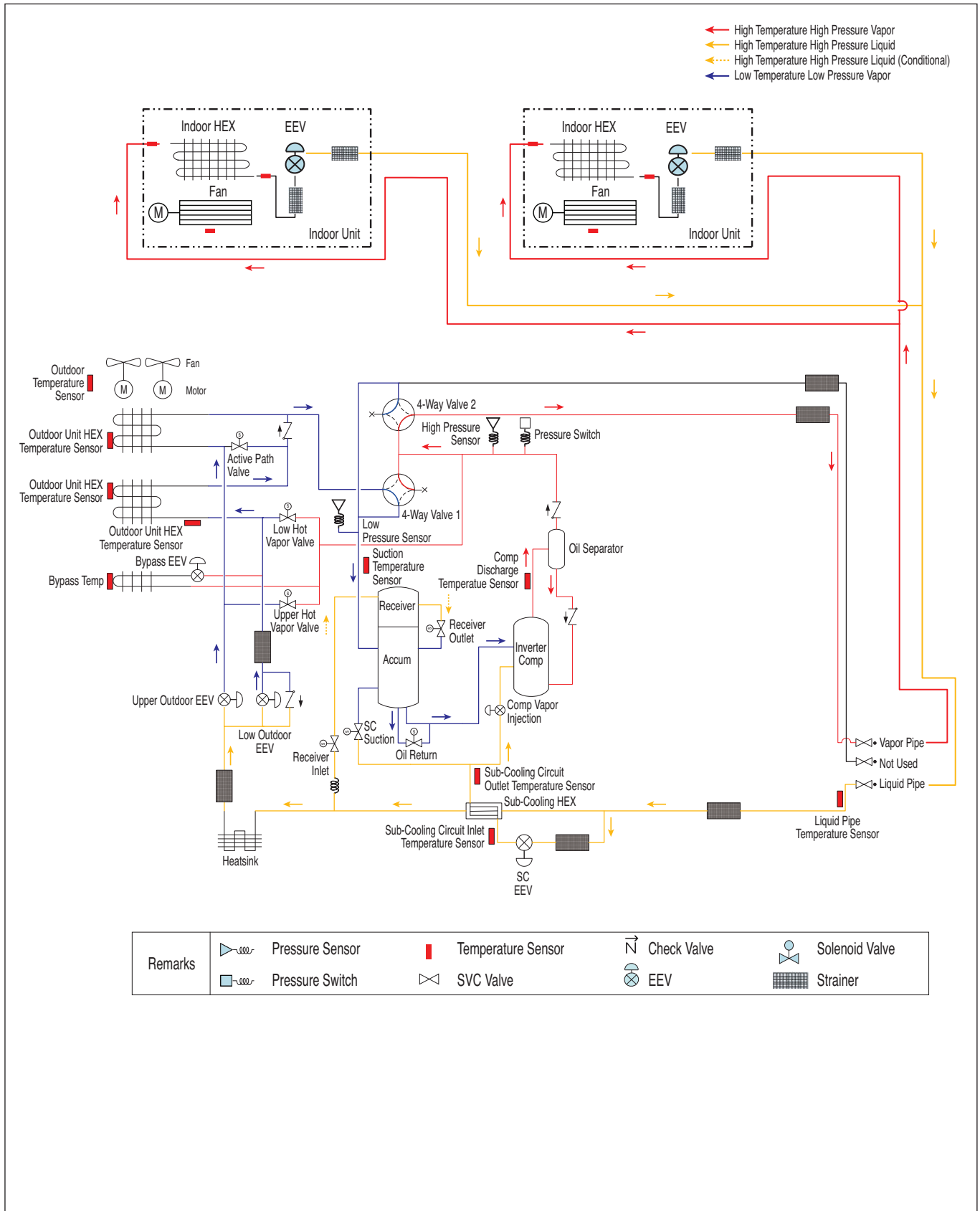

← High Temperature High Pressure Vapor
← High Temperature High Pressure Liquid
← High Temperature High Pressure Liquid (Conditional)
← Low Temperature Low Pressure Vapor

Outdoor Unit Product Data

Remarks		Pressure Sensor		Temperature Sensor		Check Valve		Solenoid Valve
		Pressure Switch		SVC Valve		EEV		Strainer

REFRIGERANT FLOW DIAGRAMS

MULTI V™ 5

ARUM072CTE5, 096CTE5, 121CTE5

Heat Pump Operation — Oil Return and Defrost Operation

MULTI V 5 Outdoor Unit Engineering Manual

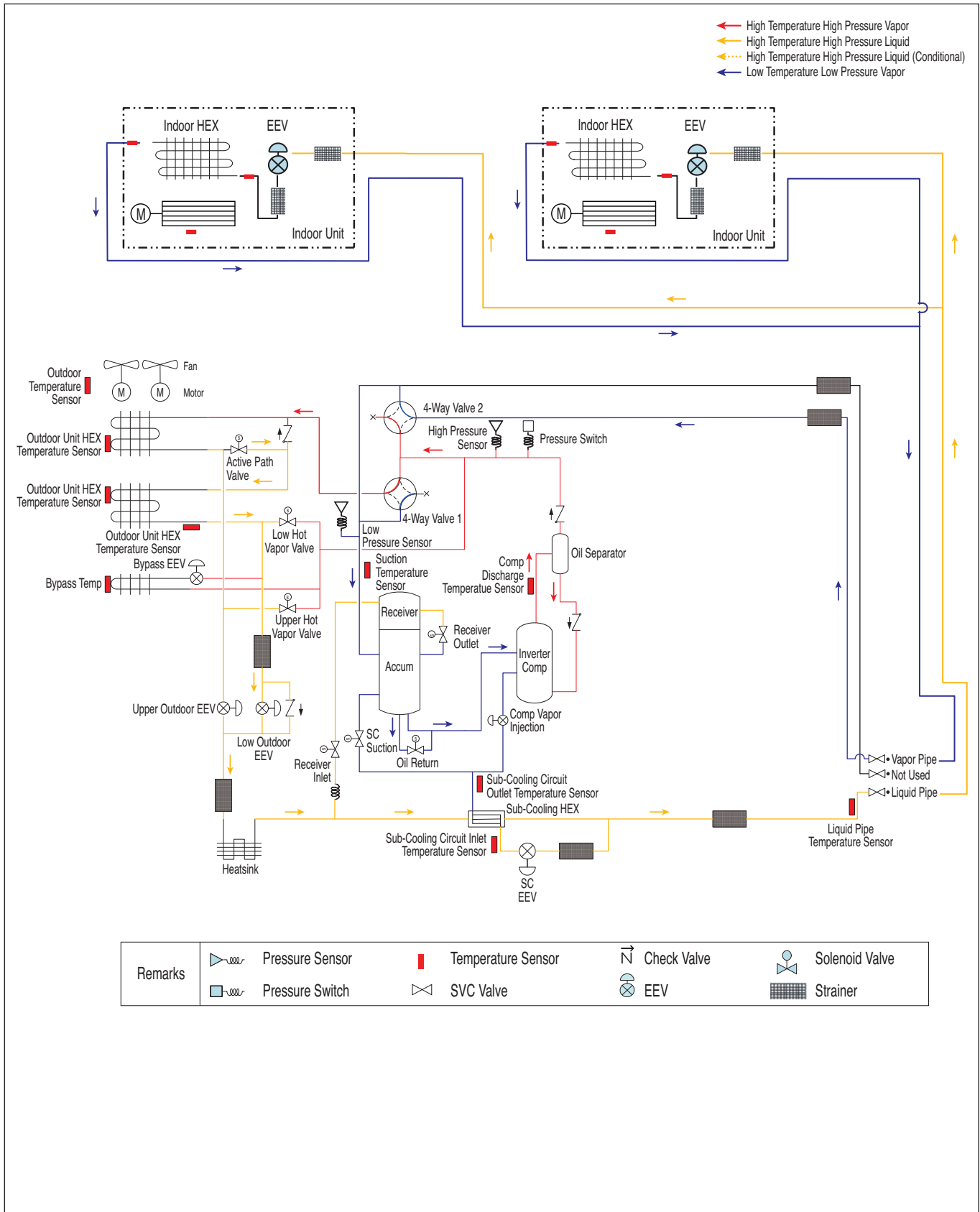

Heat Pump Operation — Upper Heat Exchanger Defrost Operation

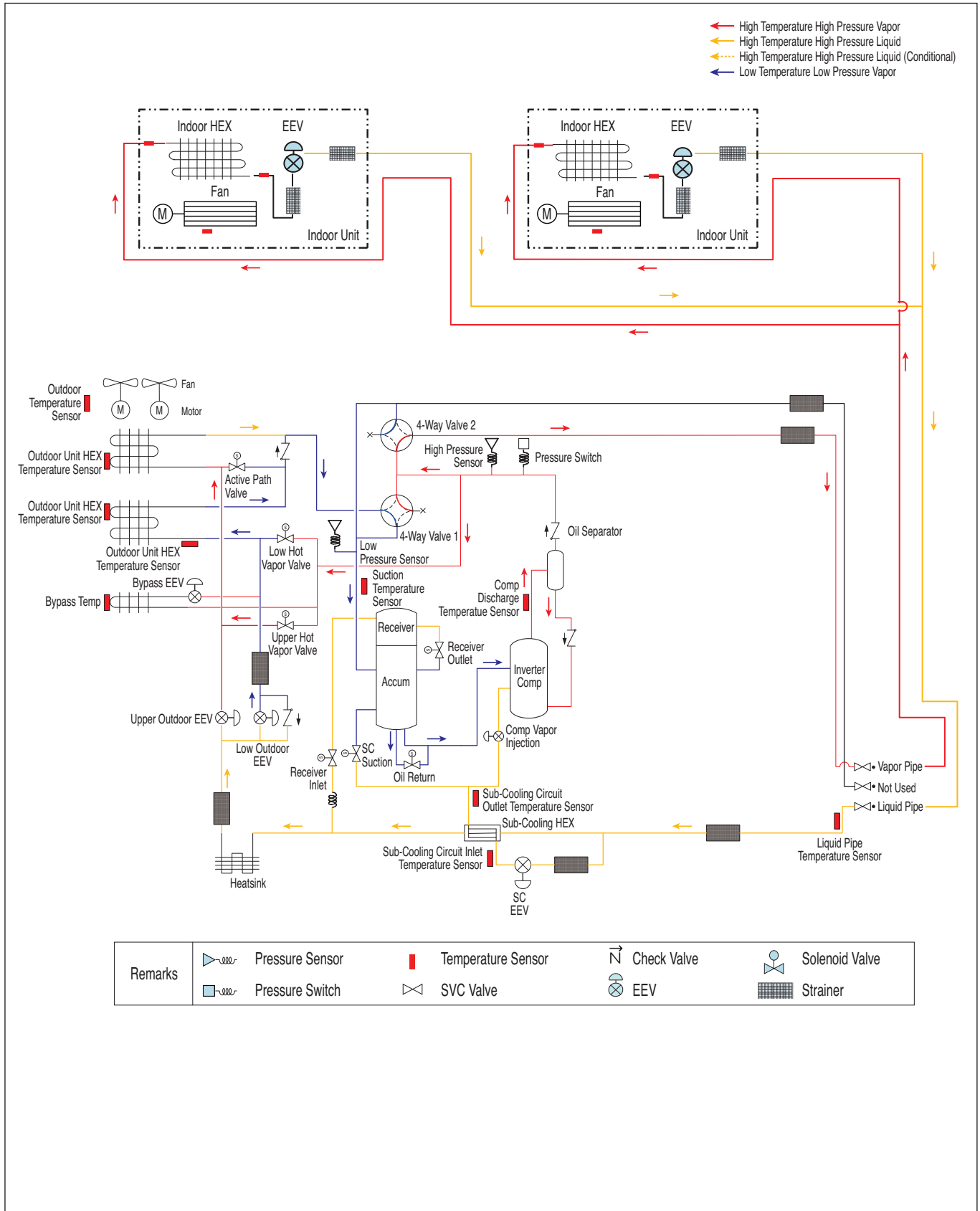

Outdoor Unit Product Data

REFRIGERANT FLOW DIAGRAMS

MULTI V™ 5

ARUM072CTE5, 096CTE5, 121CTE5

Heat Pump Operation — Low Heat Exchanger Defrost Operation

MULTI V 5 Outdoor Unit Engineering Manual

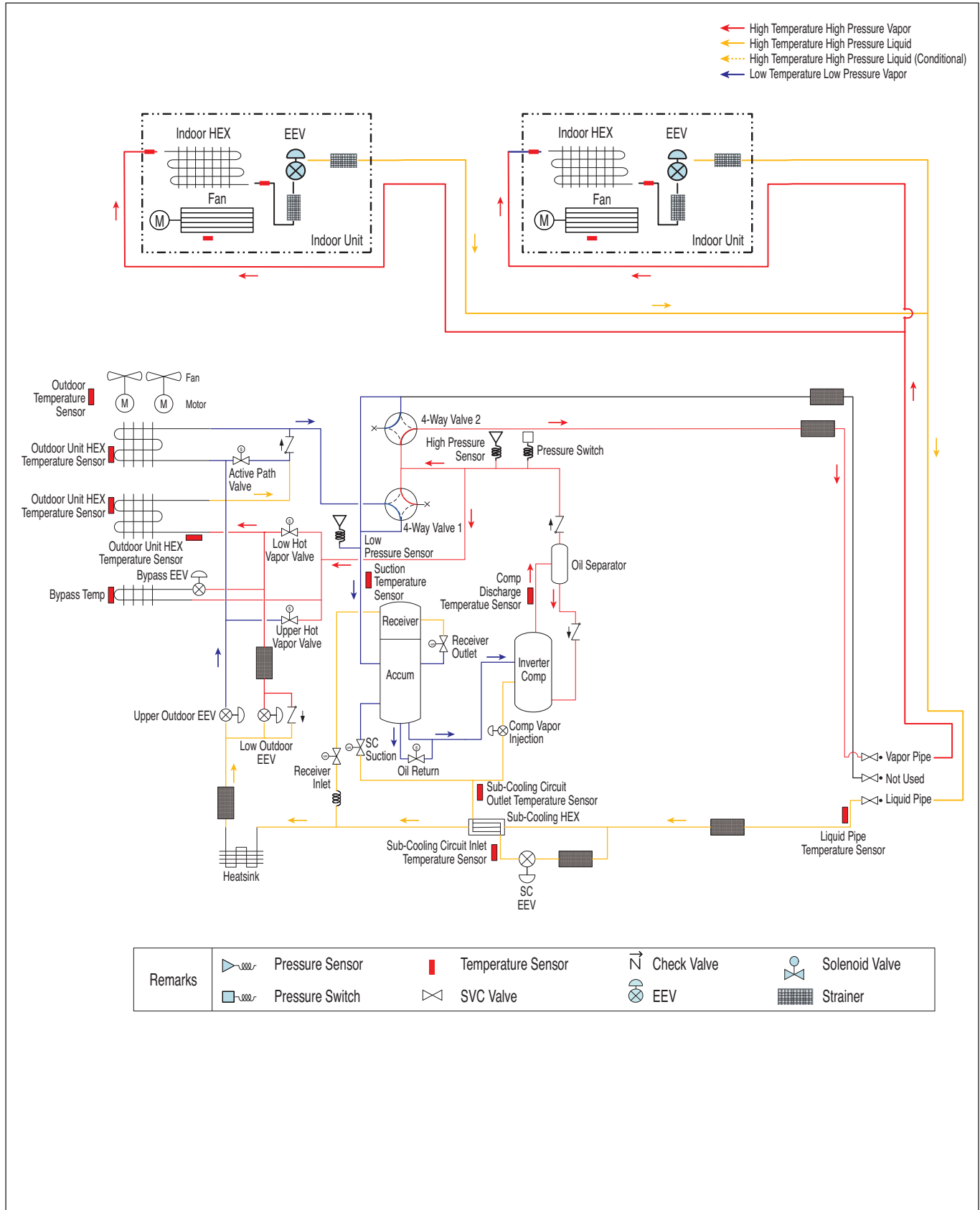

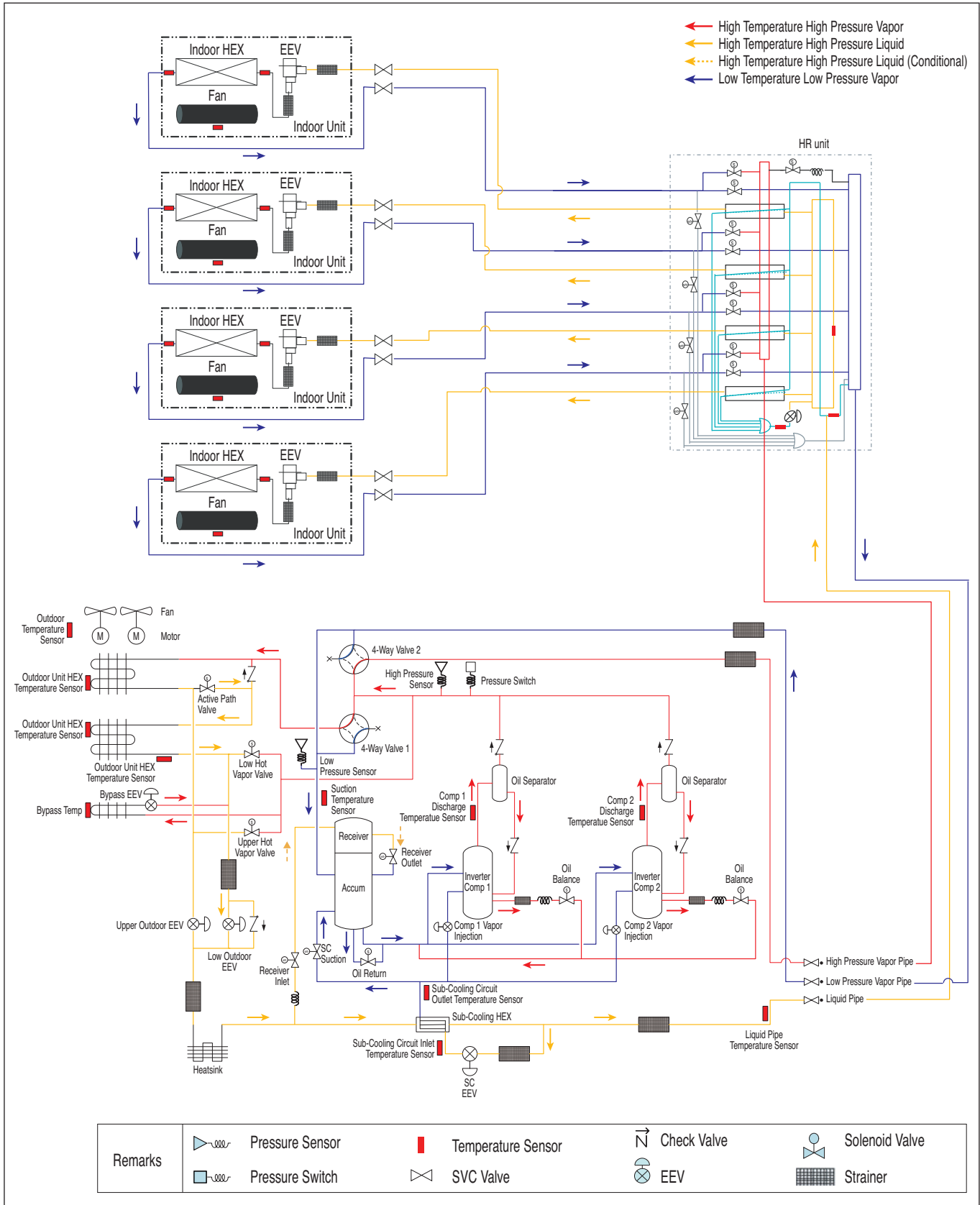

REFRIGERANT FLOW DIAGRAMS

MULTI V™ 5

ARUM144CTE5, 168CTE5, 192CTE5, 216CTE5, 241CTE5

Heat Recovery Operation — Heating Mode

MULTI V 5 Outdoor Unit Engineering Manual

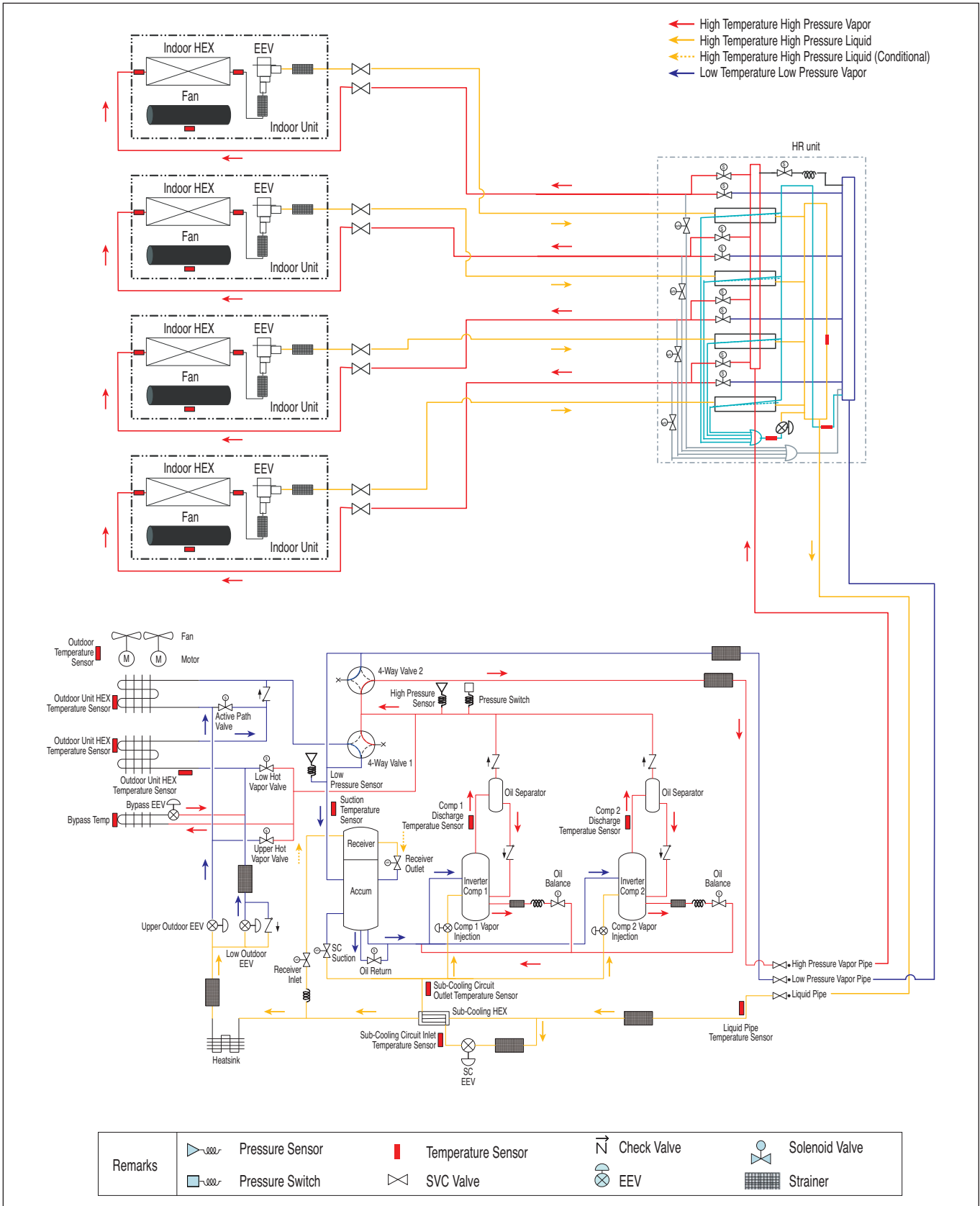

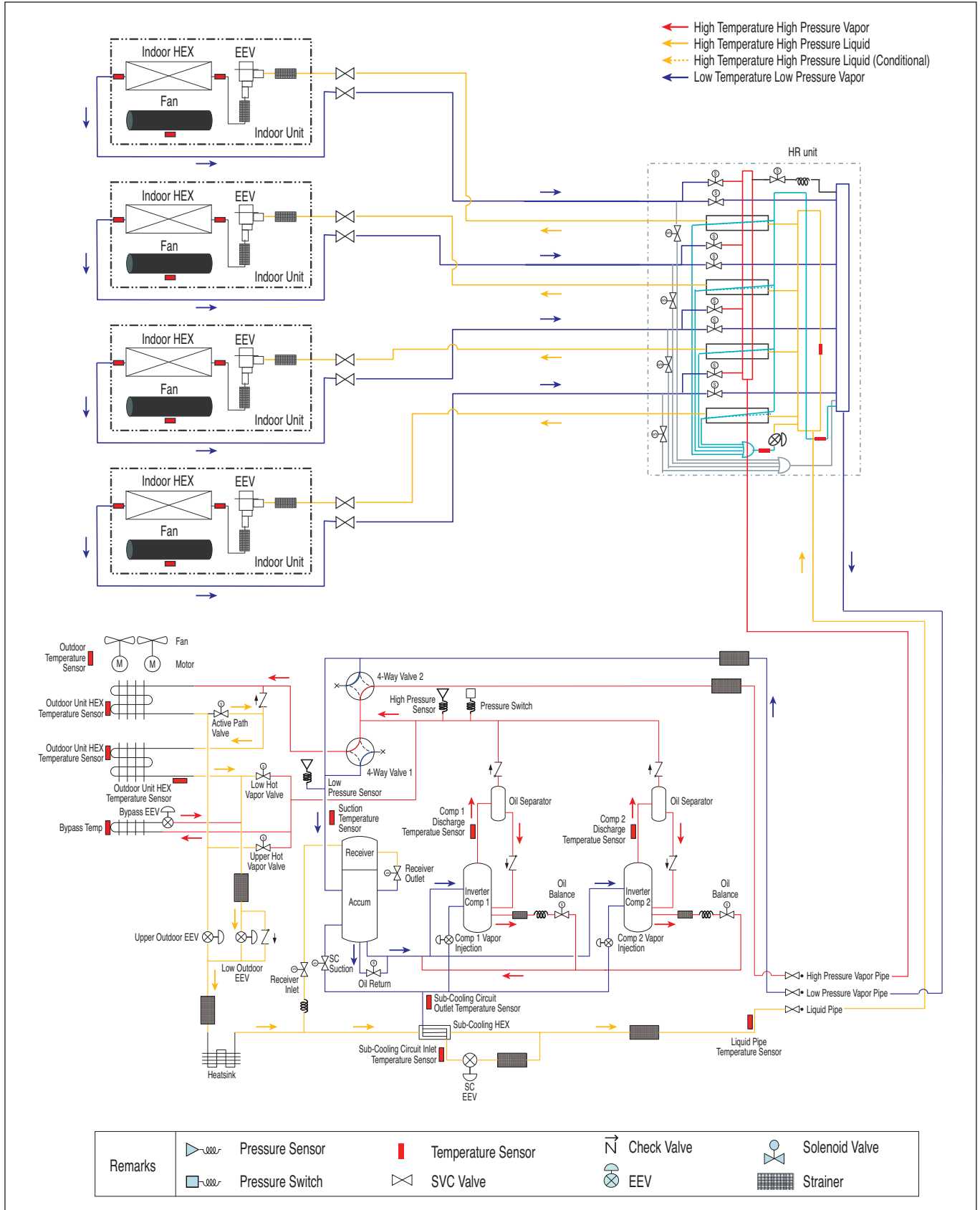

Outdoor Unit Product Data

REFRIGERANT FLOW DIAGRAMS

MULTI V™ 5

ARUM144CTE5, 168CTE5, 192CTE5, 216CTE5, 241CTE5

Heat Recovery Operation — Cooling-based Simul. Operation

MULTI V 5 Outdoor Unit Engineering Manual

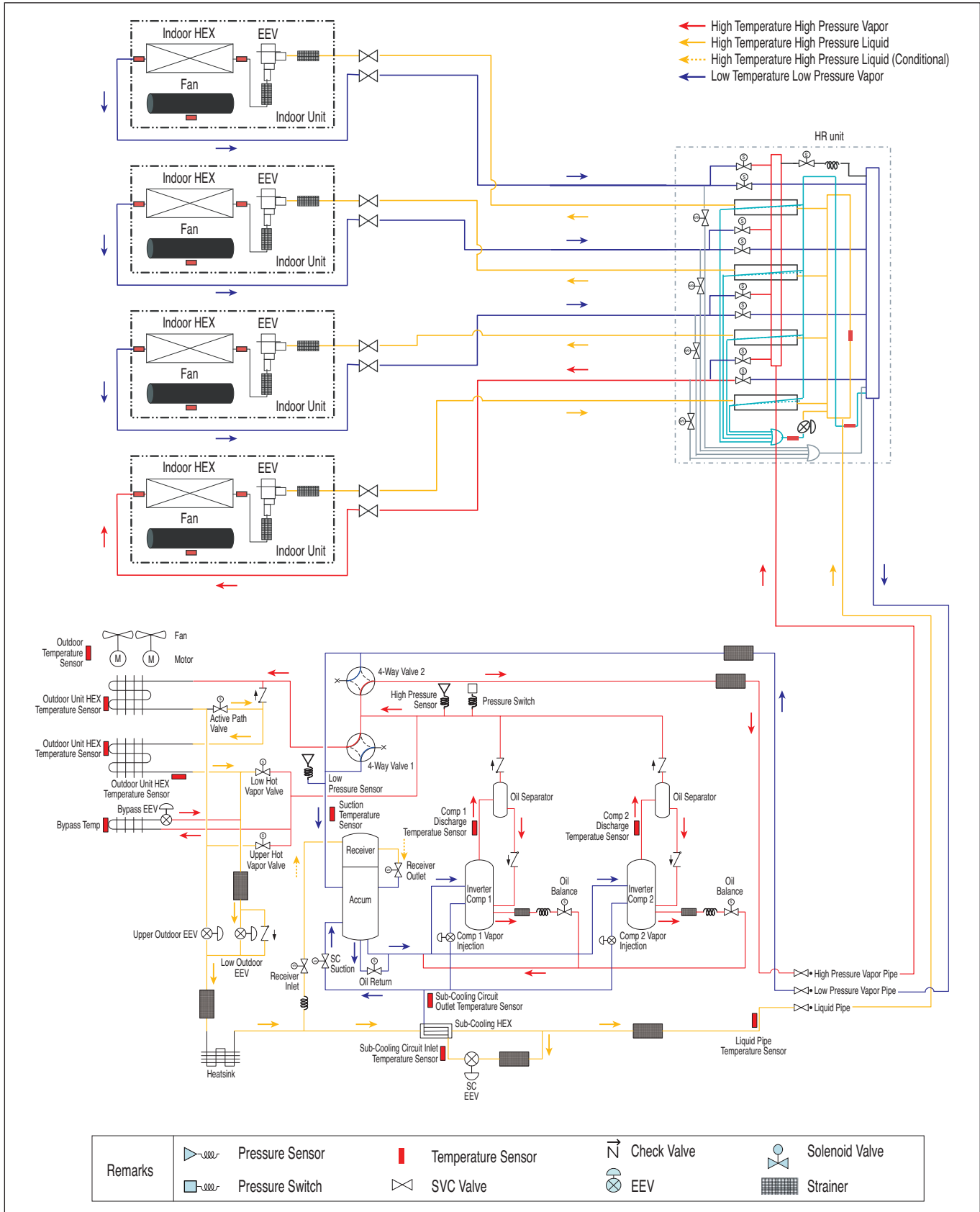

Due to our policy of continuous product innovation, some specifications may change without notification.
 © LG Electronics Canada, Inc., North York, ON. All rights reserved. "LG" is a registered trademark of LG Corp.

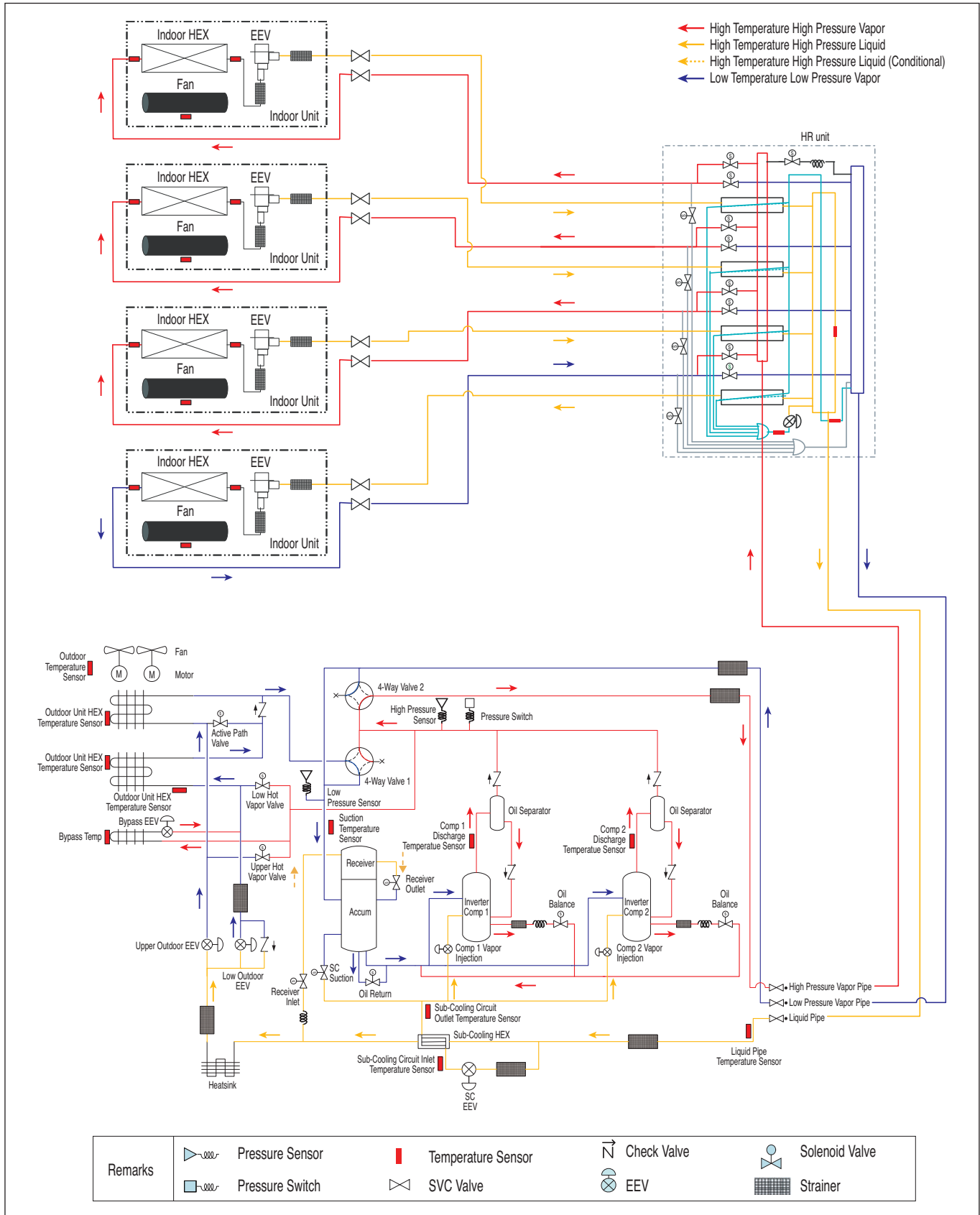

Outdoor Unit Product Data

REFRIGERANT FLOW DIAGRAMS

MULTI V™ 5

ARUM144CTE5, 168CTE5, 192CTE5, 216CTE5, 241CTE5

Heat Recovery Operation — Balanced Simul. Operation

MULTI V 5 Outdoor Unit Engineering Manual

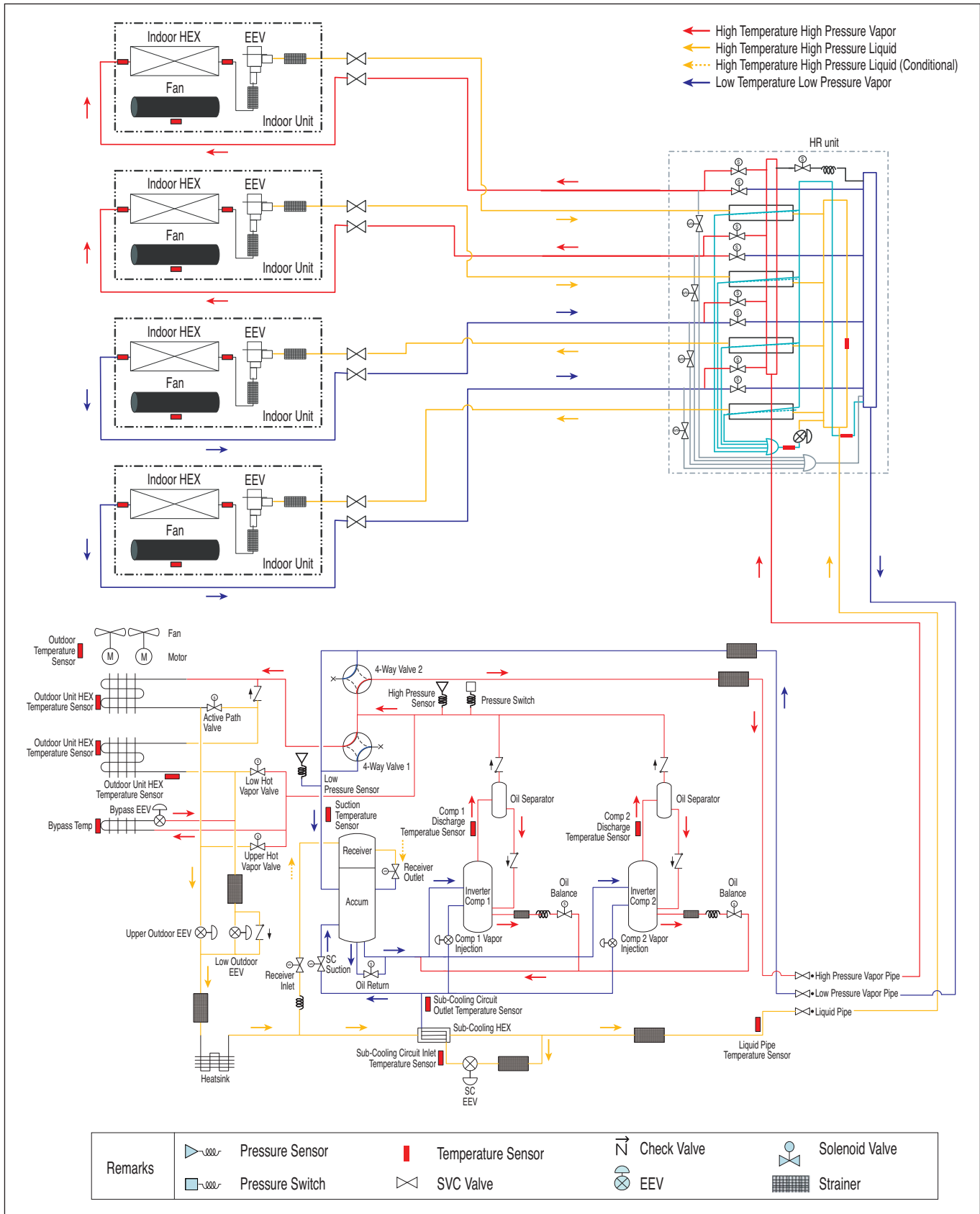

Heat Recovery Operation — Upper Heat Exchanger Defrost Operation

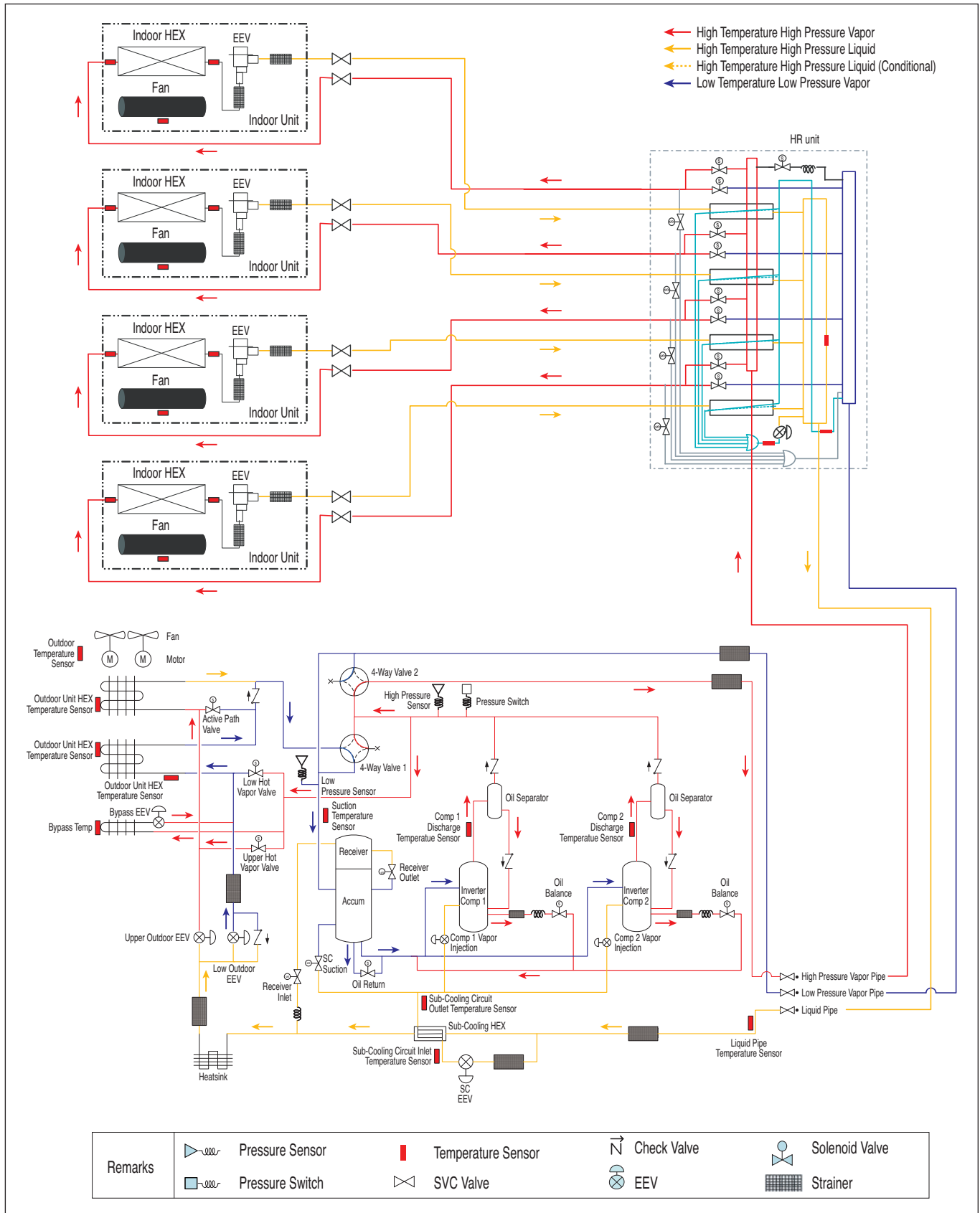

Outdoor Unit Product Data

REFRIGERANT FLOW DIAGRAMS

MULTI V™ 5

ARUM144CTE5, 168CTE5, 192CTE5, 216CTE5, 241CTE5

Heat Recovery Operation — Low Heat Exchanger Defrost Operation

MULTI V 5 Outdoor Unit Engineering Manual

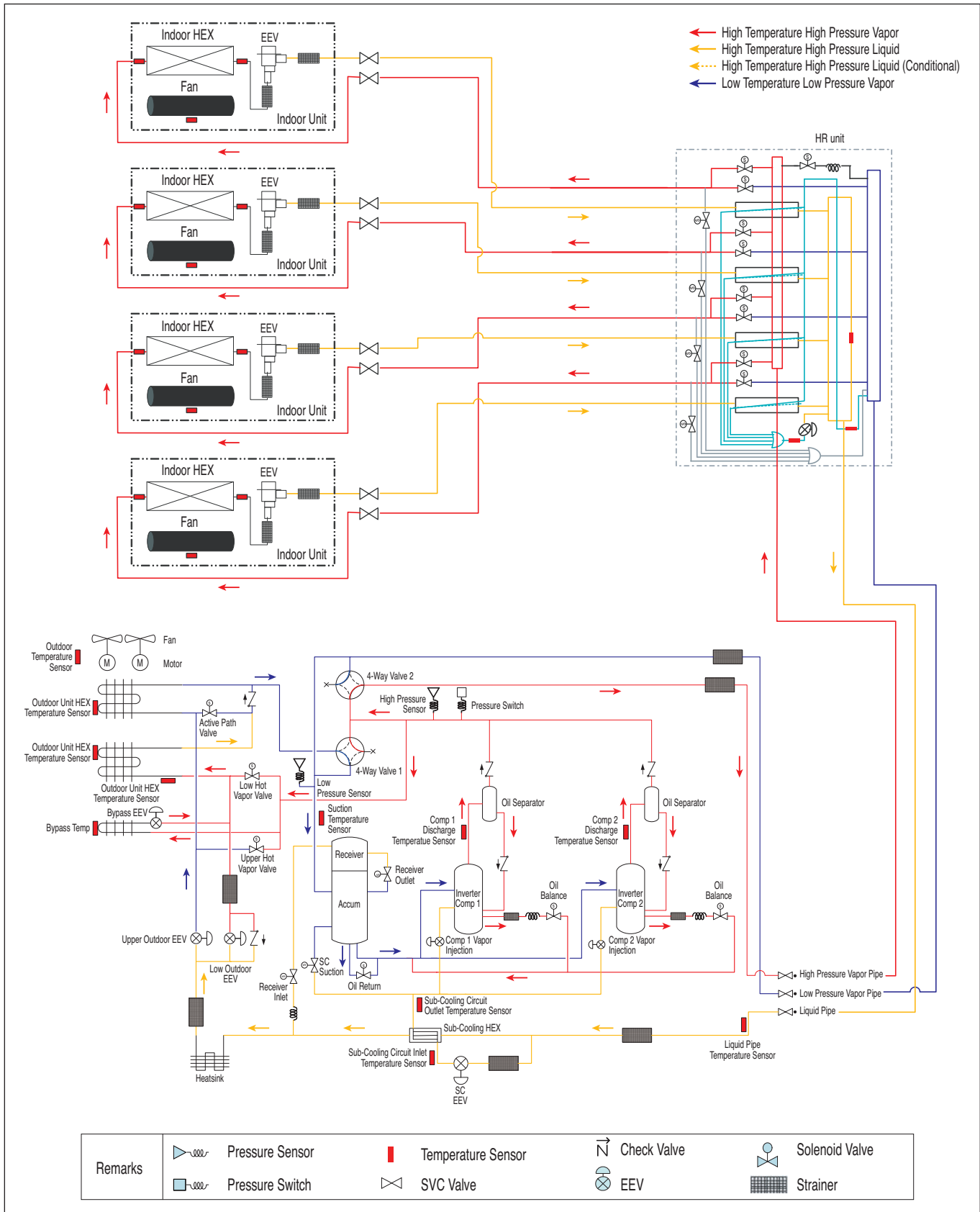

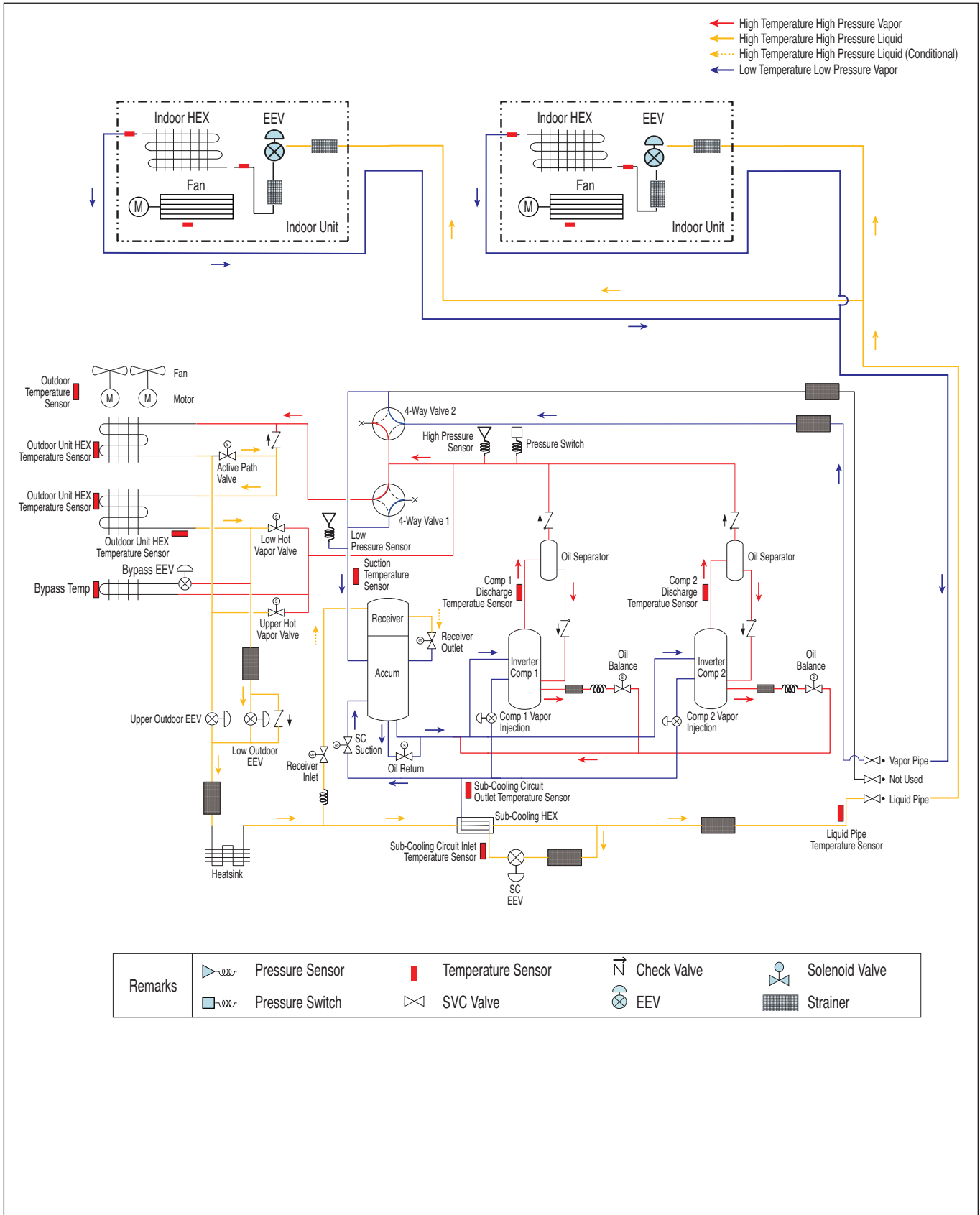

- High Temperature High Pressure Vapor
- High Temperature High Pressure Liquid
- High Temperature High Pressure Liquid (Conditional)
- Low Temperature Low Pressure Vapor

Outdoor Unit Product Data

Remarks		Pressure Sensor		Temperature Sensor		Check Valve		Solenoid Valve
		Pressure Switch		SVC Valve		EEV		Strainer

REFRIGERANT FLOW DIAGRAMS

MULTI V™ 5

ARUM144CTE5, 168CTE5, 192CTE5, 216CTE5, 241CTE5

Heat Pump Operation — Heating Mode

MULTI V 5 Outdoor Unit Engineering Manual

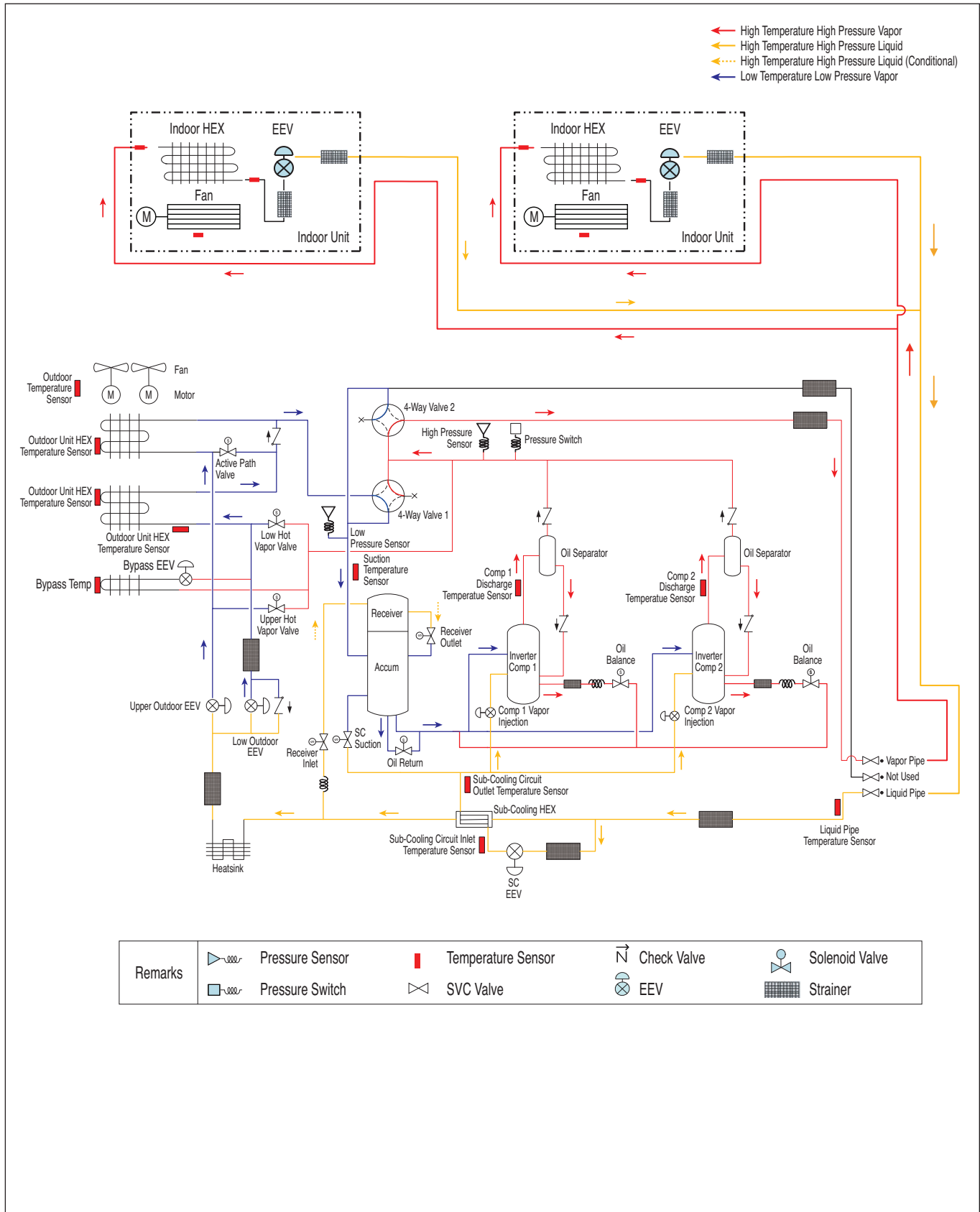

ARUM144CTE5, 168CTE5, 192CTE5, 216CTE5, 241CTE5
Heat Pump Operation — Oil Return and Defrost Operation

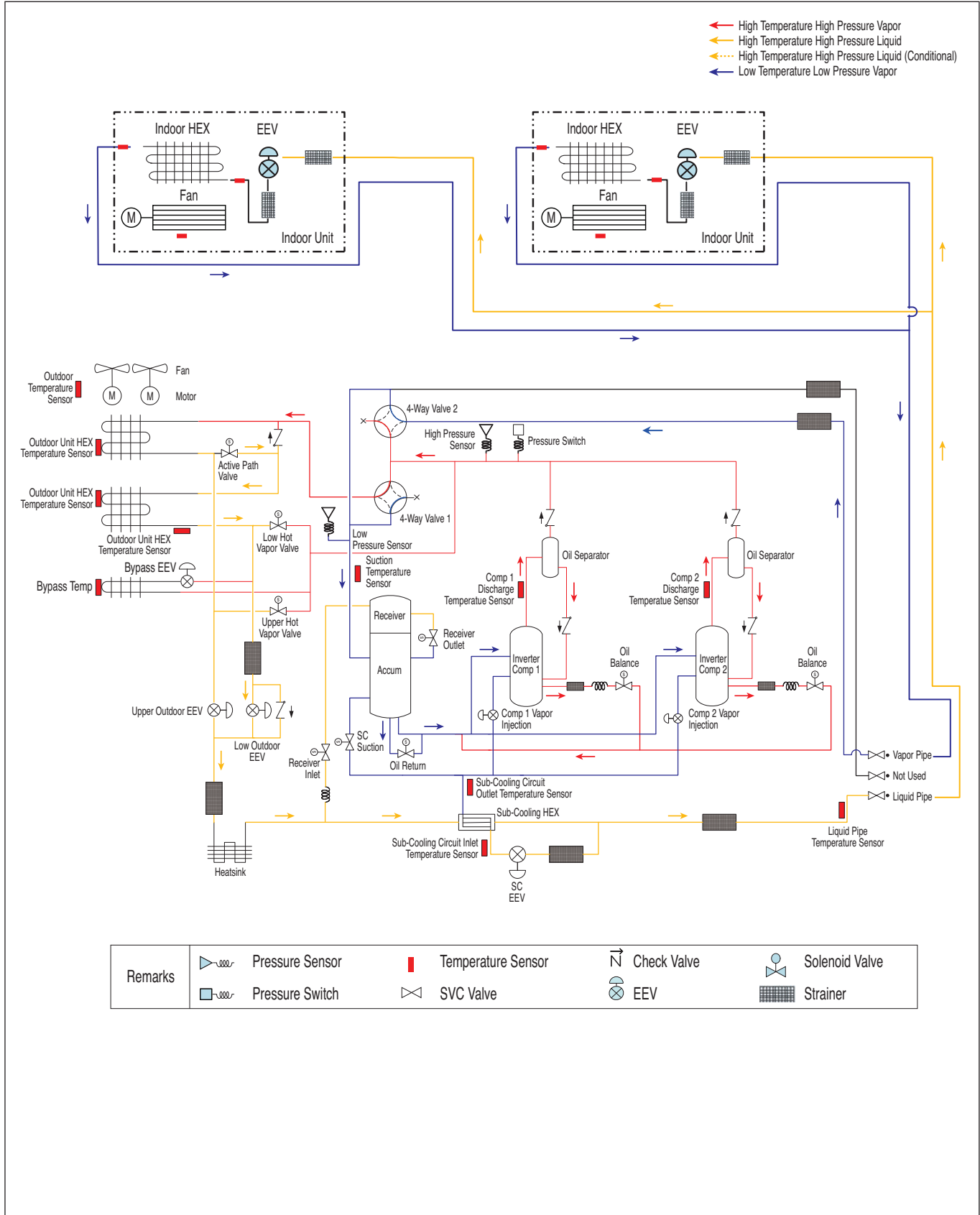

Outdoor Unit Product Data

REFRIGERANT FLOW DIAGRAMS

MULTI V™ 5

ARUM144CTE5, 168CTE5, 192CTE5, 216CTE5, 241CTE5

Heat Pump Operation — Lower Heat Exchanger Defrost Operation

MULTI V 5 Outdoor Unit Engineering Manual

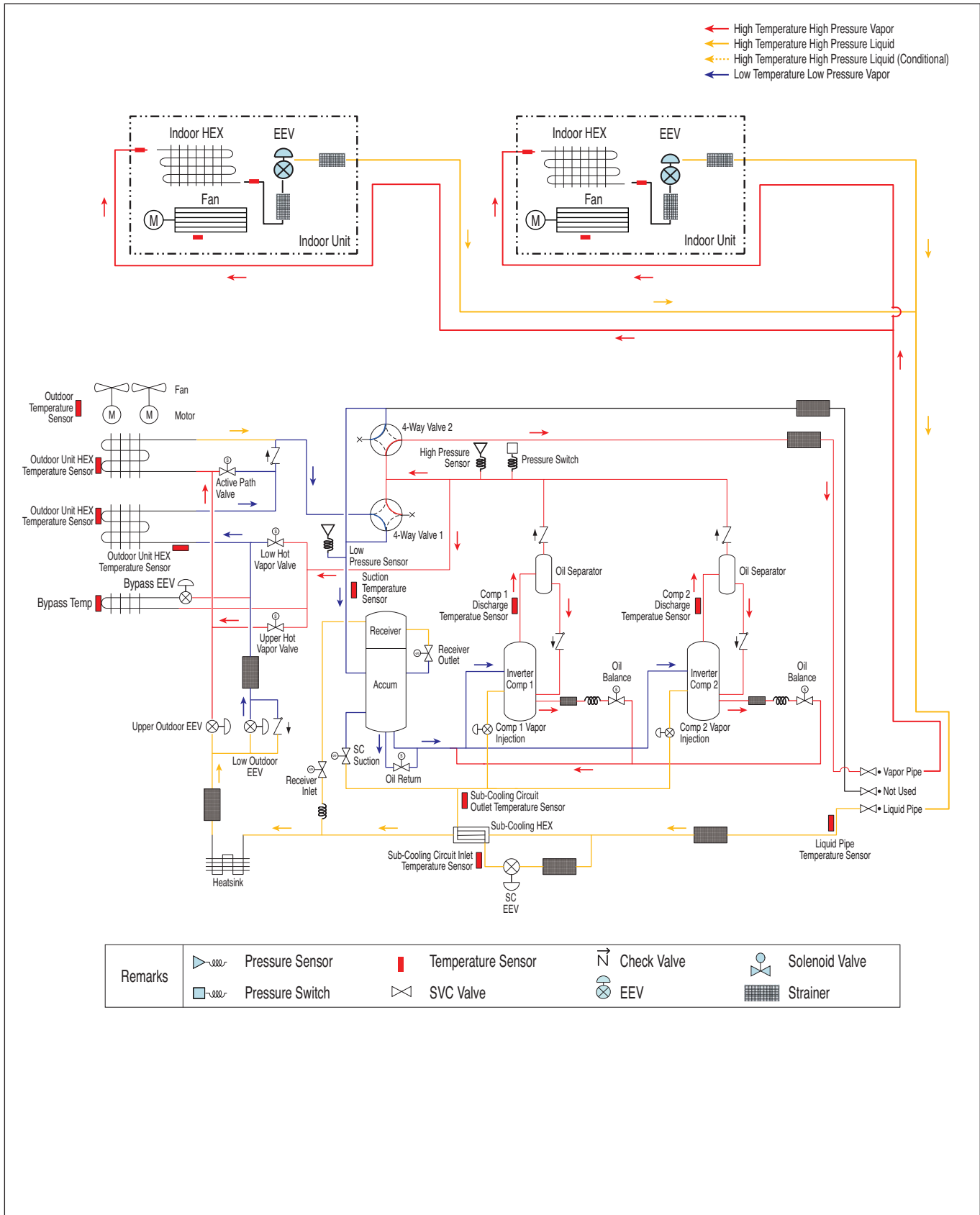

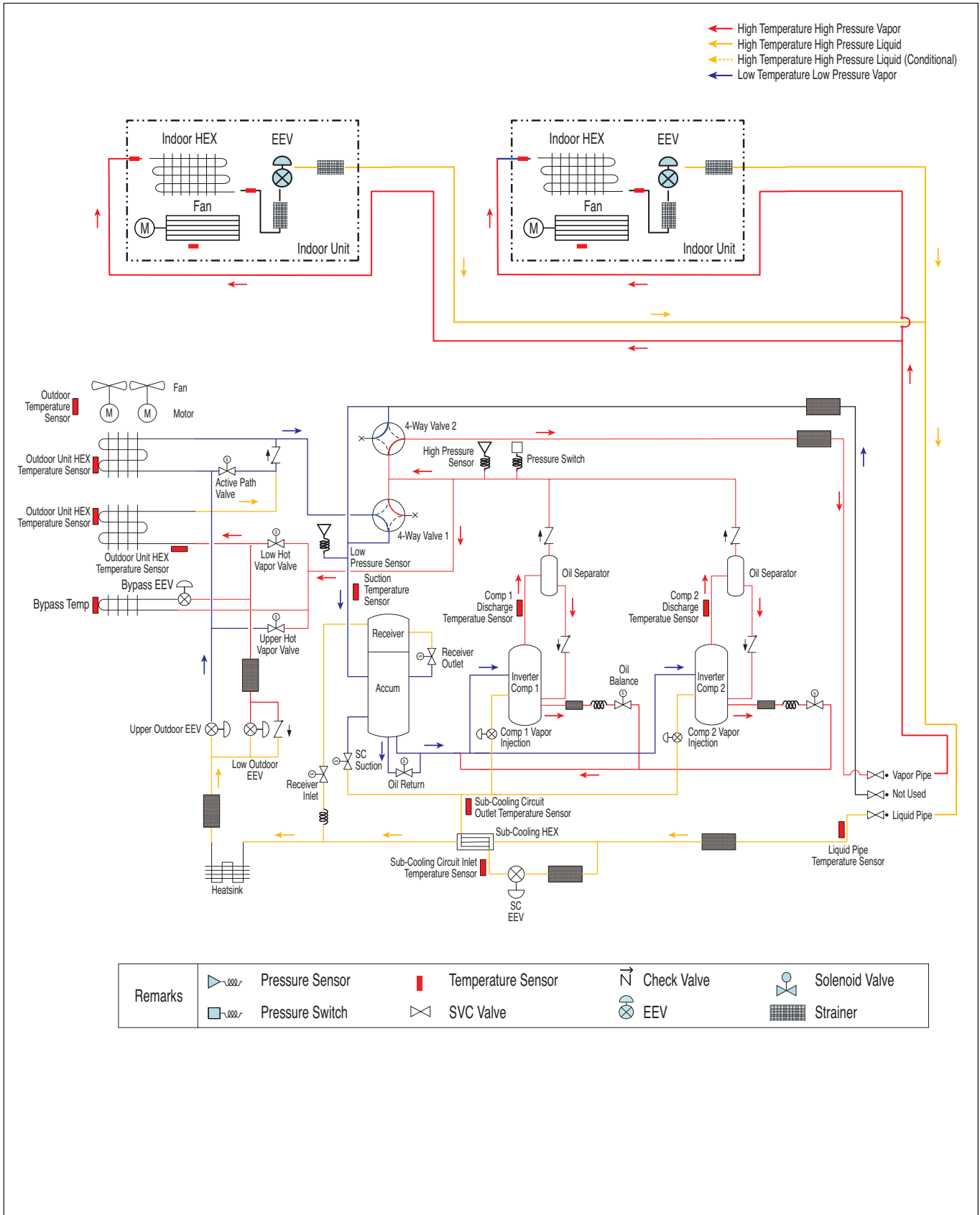

Outdoor Unit Product Data

Sound Pressure Levels

Table 8: Outdoor Unit Sound Pressure Levels.

Outdoor Unit Models		dB(A)
Nominal Tons	575V	
6	ARUM072CTE5	58.0
8	ARUM096CTE5	58.0
10	ARUM121CTE5	59.0
12	ARUM144CTE5	60.0
14	ARUM168CTE5	61.0
16	ARUM192CTE5	62.0
18	ARUM216CTE5	64.0
20	ARUM241CTE5	65.0
22	ARUM264CTE5	63.0
24	ARUM288CTE5	63.0
26	ARUM312CTE5	65.0
28	ARUM336CTE5	65.0
30	ARUM360CTE5	66.0
32	ARUM384CTE5	66.0
34	ARUM408CTE5	66.0
36	ARUM432CTE5	66.0
38	ARUM456CTE5	66.0
40	ARUM480CTE5	67.0
42	ARUM504CTE5	67.0

Figure 3: Sound Pressure Measurement Location.

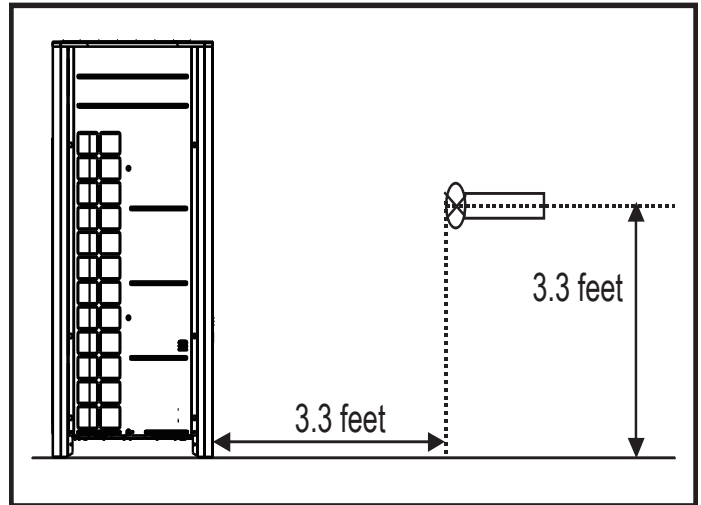

- Measurement taken 3.3' above finished floor, and at a distance of 3.3' from face of unit.
- Measurements taken with no attenuation and units operating at full load normal operating condition.
- Sound level will vary depending on a range of factors such as construction (acoustic absorption coefficient) of particular area in which the equipment is installed.
- Sound level may be increased in static pressure mode or if an air guide is used.
- Sound levels are measured in dB(A)±3.
- Tested in anechoic chamber per ISO Standard 3745.

Figure 4: ARUM072-096-121CTE5 Sound Pressure Levels.

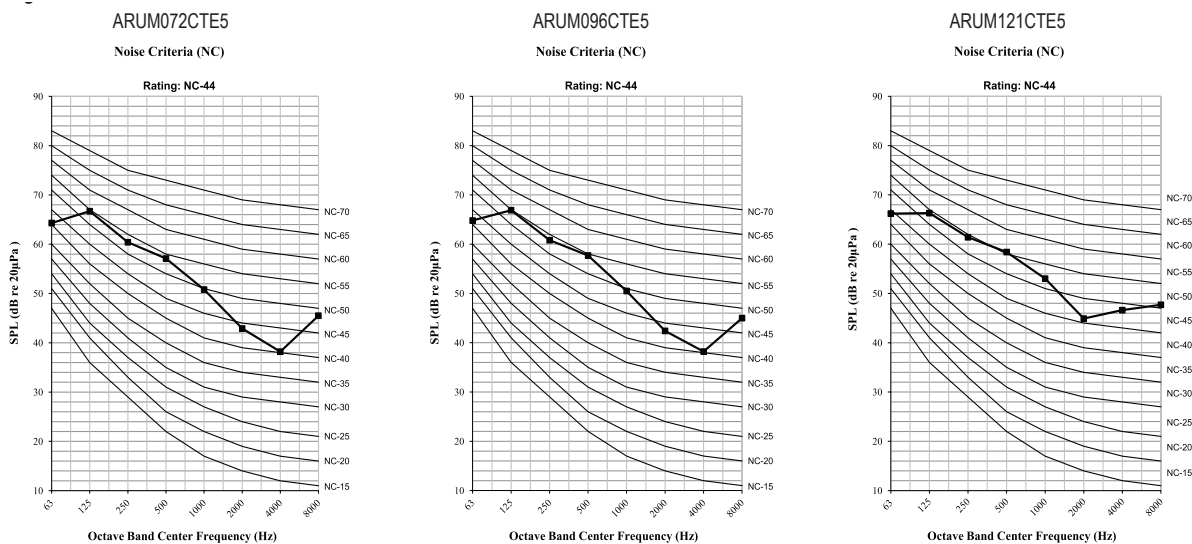

Figure 5: ARUM144-168-192CTE5 Sound Pressure Levels.

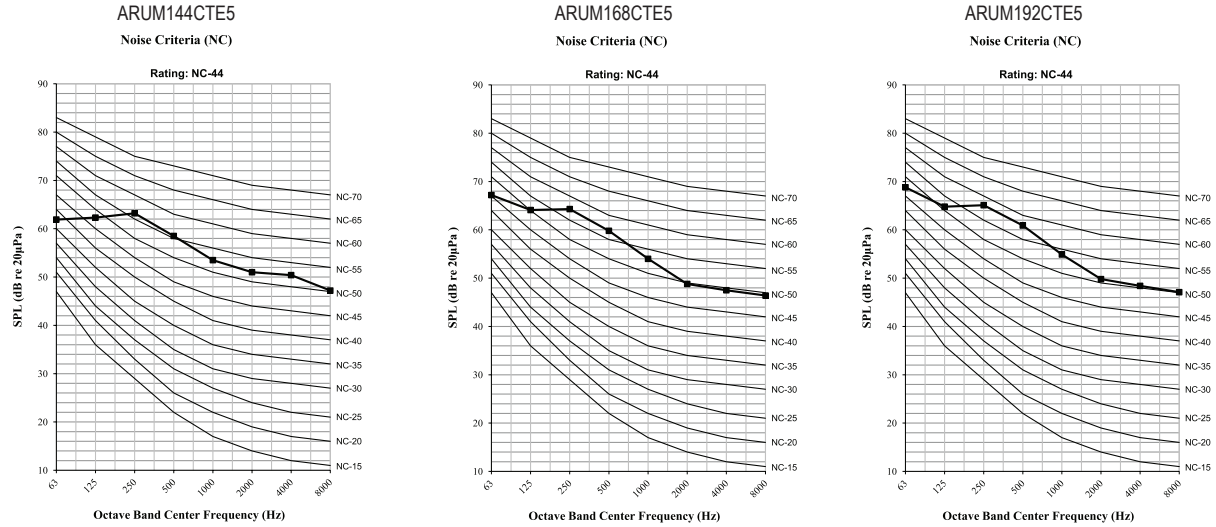

Figure 6: ARUM216-241-264CTE5 Sound Pressure Levels.

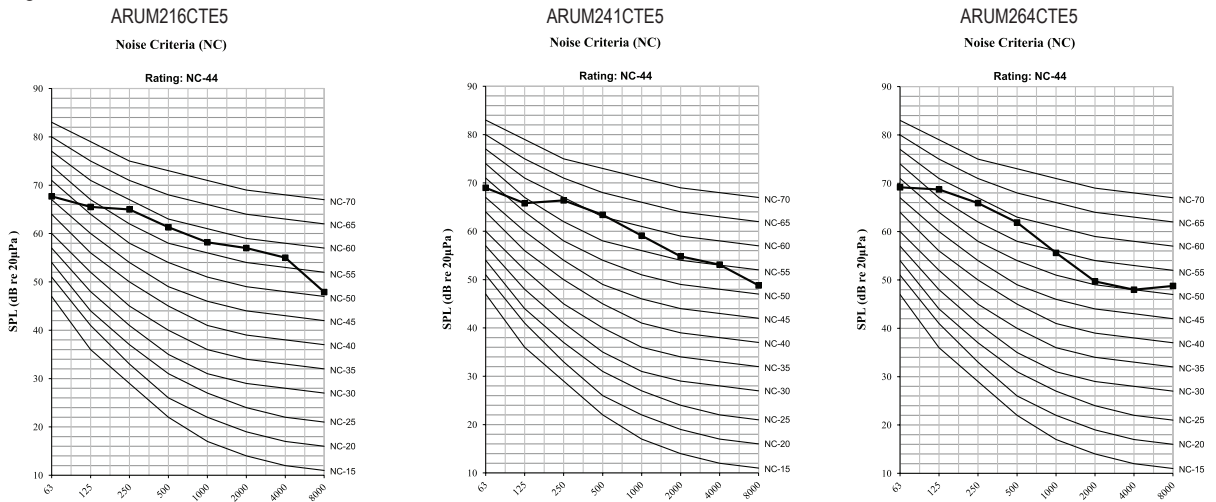
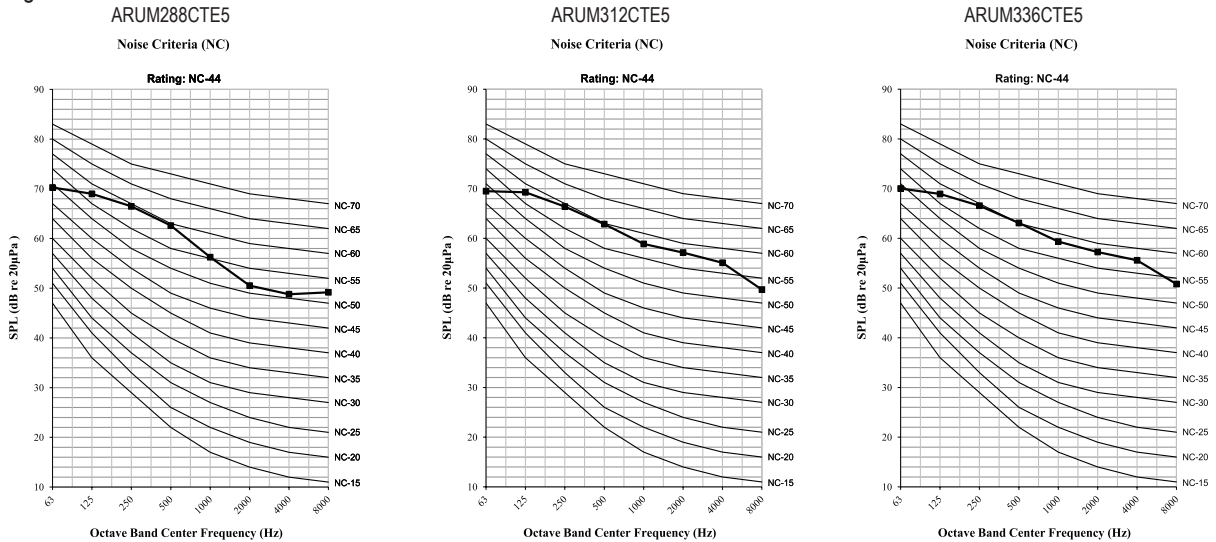

Figure 7: ARUM288-312-336CTE5 Sound Pressure Levels.



Sound Pressure Levels

Figure 8: ARUM360-384-408CTE5 Sound Pressure Levels.

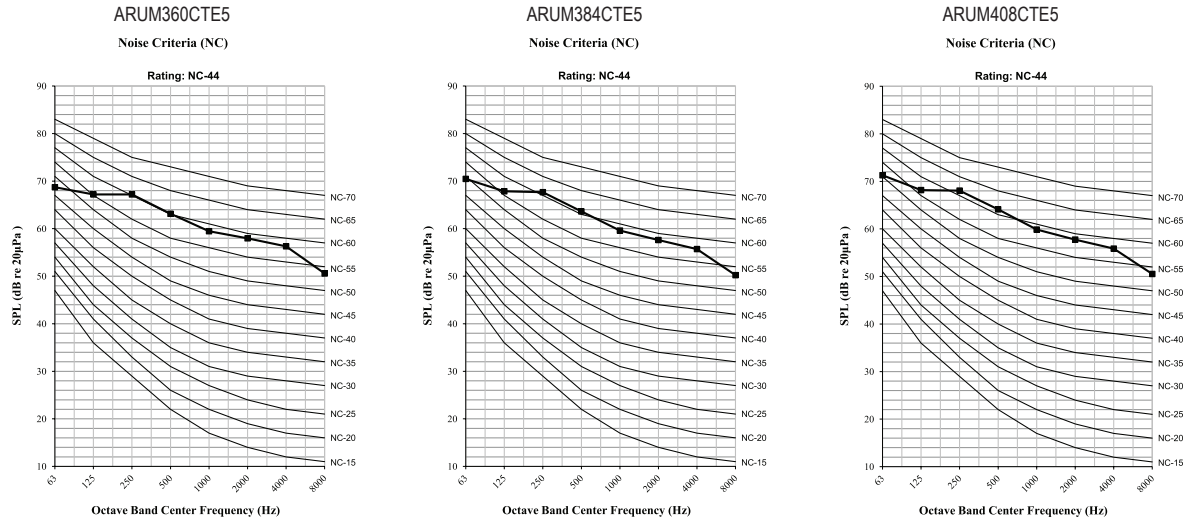

Figure 9: ARUM432-456-480CTE5 Sound Pressure Levels.

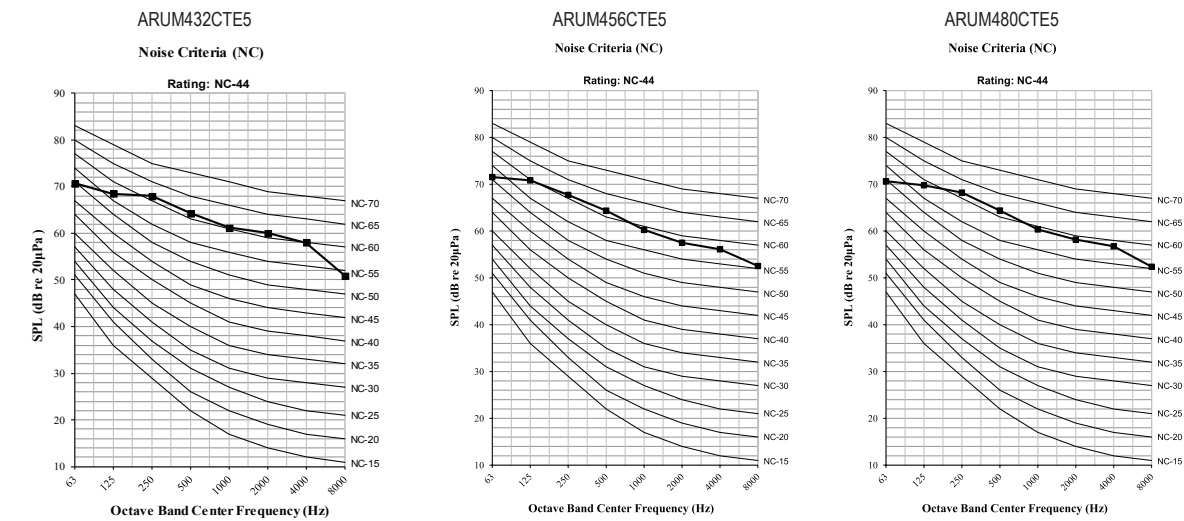

Figure 10: ARUM504CTE5 Sound Pressure Levels.

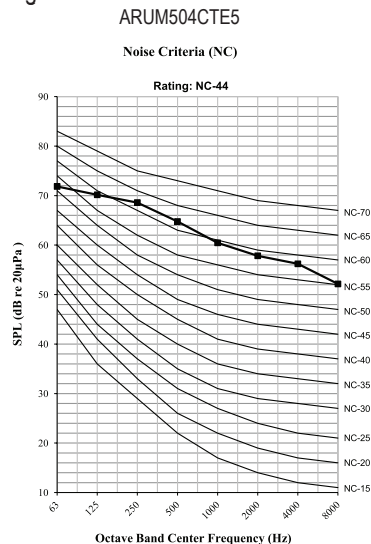
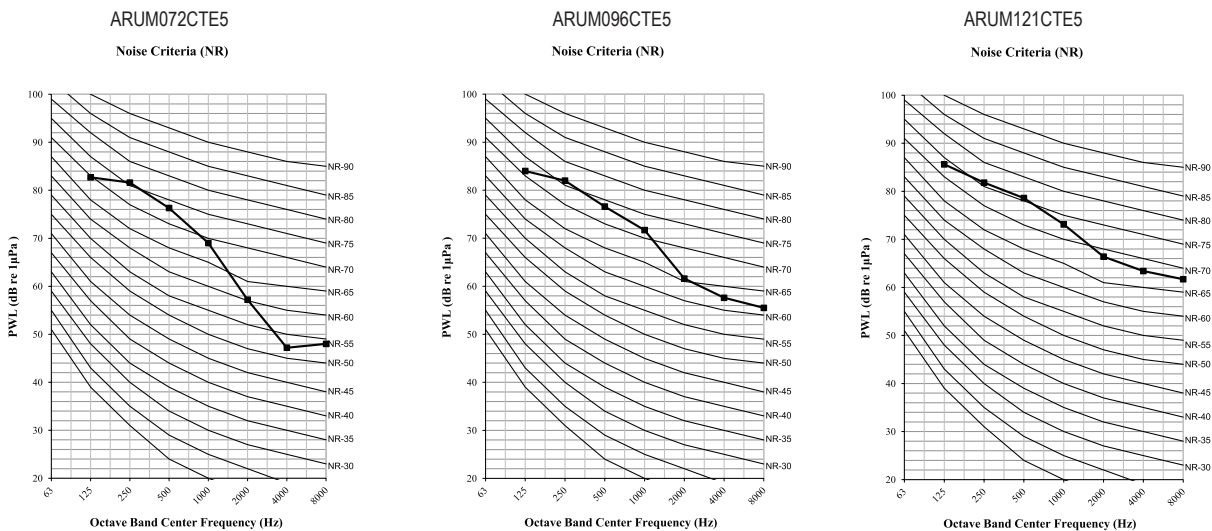

Table 9: Outdoor Unit Sound Power Levels.

Outdoor Unit Models		dB(A)
Nominal Tons	575V	
6	ARUM072CTE5	77.0
8	ARUM096CTE5	78.0
10	ARUM121CTE5	79.0
12	ARUM144CTE5	83.0
14	ARUM168CTE5	85.0
16	ARUM192CTE5	87.0
18	ARUM216CTE5	88.0
20	ARUM241CTE5	88.0
22	ARUM264CTE5	86.0
24	ARUM288CTE5	87.0
26	ARUM312CTE5	88.0
28	ARUM336CTE5	88.0
30	ARUM360CTE5	89.0
32	ARUM384CTE5	89.0
34	ARUM408CTE5	90.0
36	ARUM432CTE5	89.0
38	ARUM456CTE5	89.0
40	ARUM480CTE5	89.0
42	ARUM504CTE5	90.0

- Data is valid under diffuse field conditions.
- Data is valid under nominal operating conditions.
- Sound level may be increased in static pressure mode or if air guide is used.
- Sound power level is measured using rated conditions, and tested in a reverberation room per ISO 3741 standards.
- Sound level will vary depending on a range of factors such as construction (acoustic absorption coefficient) of particular area in which the equipment is installed.
- Reference acoustic intensity: 0dB = 10E-6μW/m²

Figure 11: ARUM072-096-121CTE5 Sound Power Levels.



Sound Power Levels

Figure 12: ARUM144-168-192CTE5 Sound Power Levels.

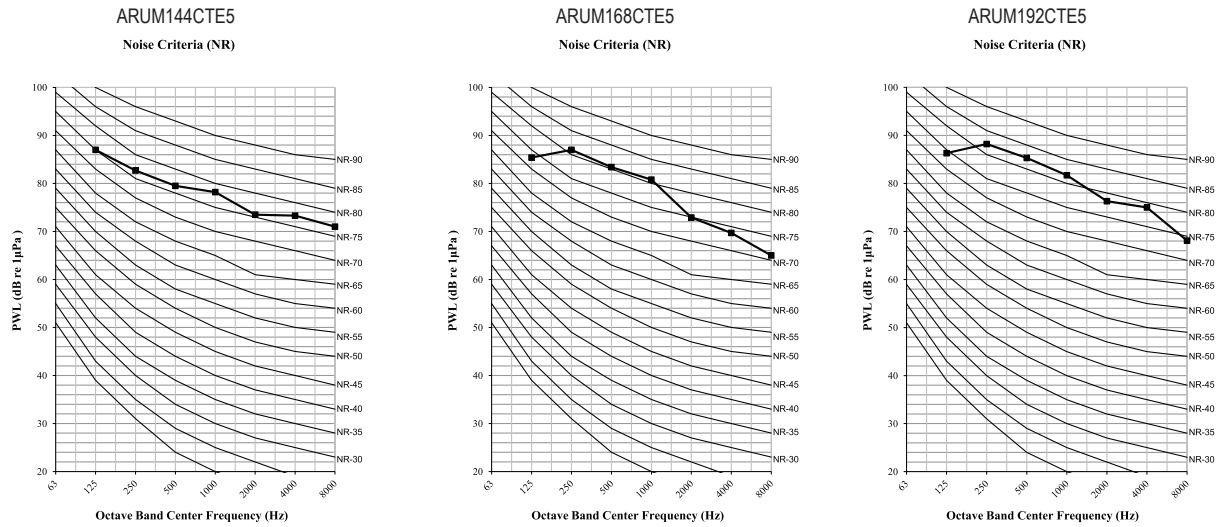

Figure 13: ARUM216-241-264CTE5 Sound Power Levels.

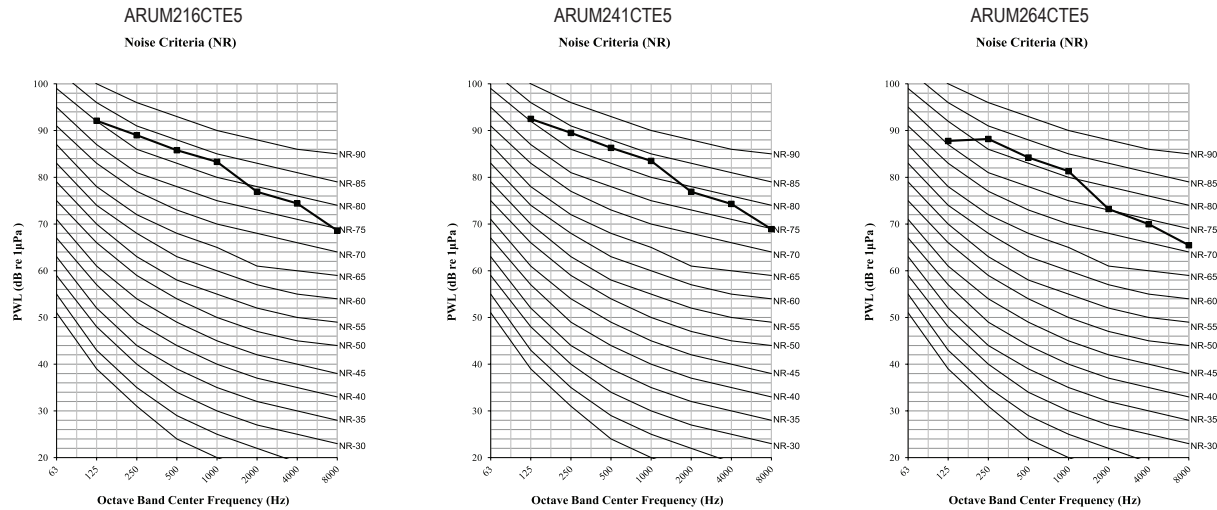

Figure 14: ARUM288-312-336CTE5 Sound Power Levels.

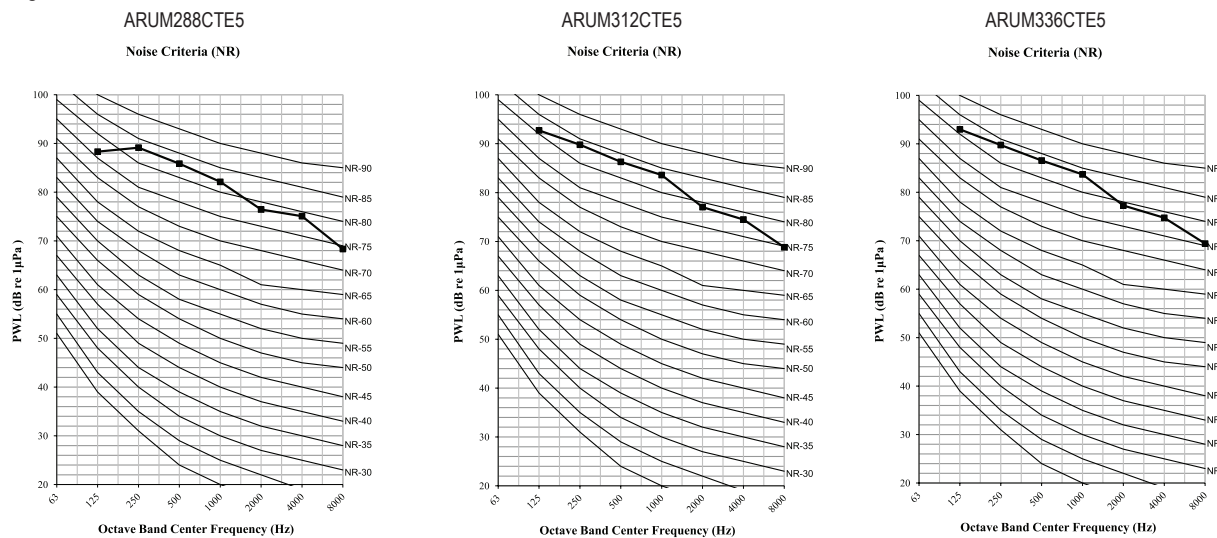

Figure 15: ARUM360-384-408CTE5 Sound Power Levels.

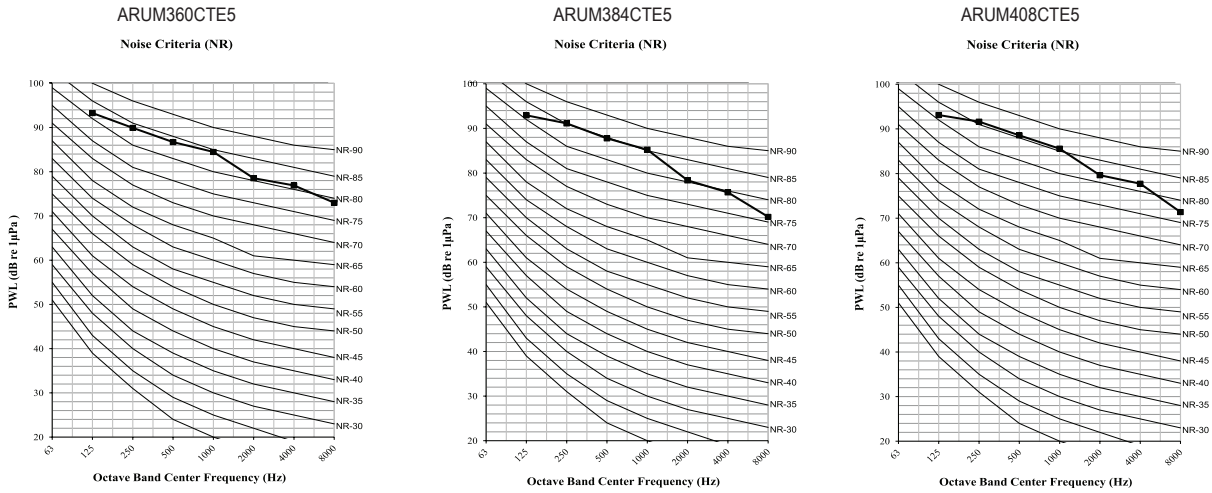

Figure 16: ARUM432-456-480CTE5 Sound Power Levels.

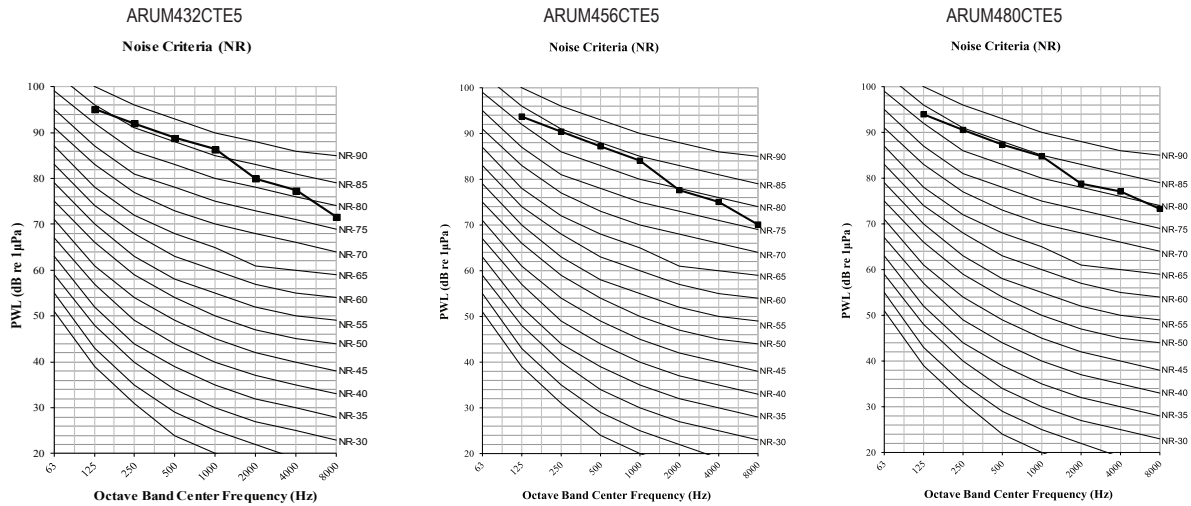
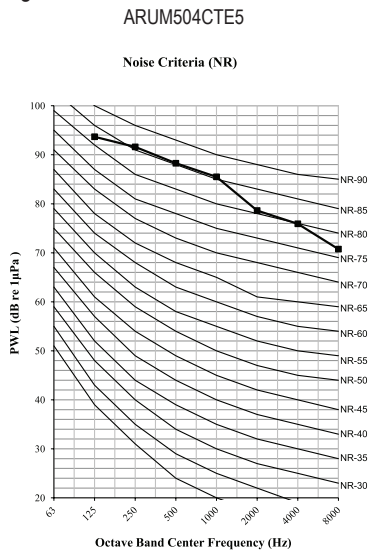

Figure 17: ARUM504CTE5 Sound Power Levels.



Indoor Unit Y-Branched for Heat Pump Operation

Unit: Inch

Models	Vapor pipe	Liquid pipe
ARBLN01621	<p>Technical drawing of the Vapor pipe for model ARBLN01621. The main assembly has a total length of 11-1/2 inches and a height of 2-15/16 inches. It features a horizontal main pipe with a branch pipe. Dimensions include I.D. 5/8 for the main pipe, I.D. 1/2 for the branch pipe, and a total length of 11-1/16 inches for the main section. A detail shows a pipe with I.D. 3/4 and O.D. 5/8, with a length of 2-3/4 inches.</p>	<p>Technical drawing of the Liquid pipe for model ARBLN01621. The main assembly has a total length of 11-1/2 inches and a height of 2-15/16 inches. It features a horizontal main pipe with a branch pipe. Dimensions include I.D. 1/4 for the main pipe, I.D. 3/8 for the branch pipe, and a total length of 11-1/16 inches for the main section. A detail shows a pipe with I.D. 1/2 and O.D. 3/8, with a length of 2-3/4 inches.</p>
ARBLN03321	<p>Technical drawing of the Vapor pipe for model ARBLN03321. The main assembly has a total length of 16-1/4 inches and a height of 3-5/16 inches. It features a horizontal main pipe with a branch pipe. Dimensions include I.D. 1 for the main pipe, I.D. 3/4 for the branch pipe, and a total length of 15-3/8 inches for the main section. Details show pipes with I.D. 7/8 and O.D. 3/4 (length 2-3/4), I.D. 1-1/8 and O.D. 1 (length 3-3/16), and I.D. 7/8 and O.D. 3/4 (length 4-3/8).</p>	<p>Technical drawing of the Liquid pipe for model ARBLN03321. The main assembly has a total length of 13-1/16 inches and a height of 2-15/16 inches. It features a horizontal main pipe with a branch pipe. Dimensions include I.D. 1/2 for the main pipe, I.D. 3/8 for the branch pipe, and a total length of 12-5/8 inches for the main section.</p>
ARBLN07121	<p>Technical drawing of the Vapor pipe for model ARBLN07121. The main assembly has a total length of 15-215/16 inches and a height of 3-13/16 inches. It features a horizontal main pipe with a branch pipe. Dimensions include I.D. 1-1/8 for the main pipe, I.D. 1-1/4 for the branch pipe, and a total length of 14-13/16 inches for the main section. Details show pipes with I.D. 1-1/8 and O.D. 7/8 (length 4-3/4), I.D. 1-3/8 and O.D. 1-1/4 (length 3-9/16), and I.D. 7/8 and O.D. 3/4 (length 4-3/4).</p>	<p>Technical drawing of the Liquid pipe for model ARBLN07121. The main assembly has a total length of 15-1/2 inches and a height of 3-5/16 inches. It features a horizontal main pipe with a branch pipe. Dimensions include I.D. 1/2 for the main pipe, I.D. 3/4 for the branch pipe, and a total length of 14-5/8 inches for the main section. Details show pipes with O.D. 1/2 and I.D. 1/4 (length 4-3/8), and I.D. 3/8 and O.D. 1/2 (length 2-3/4).</p>
ARBLN14521	<p>Technical drawing of the Vapor pipe for model ARBLN14521. The main assembly has a total length of 20-3/8 inches and a height of 4-15/16 inches. It features a horizontal main pipe with a branch pipe. Dimensions include I.D. 1-3/8 for the main pipe, I.D. 1-1/2 for the branch pipe, and a total length of 18-9/16 inches for the main section. Details show pipes with I.D. 3/4 and I.D. 5/8 (length 4-3/4), I.D. 1-5/8 and O.D. 1-1/2 (length 3-9/16), I.D. 1-3/8 and O.D. 1-3/8 (length 5-1/8), I.D. 1-1/2 and I.D. 1-5/8 (length 5-1/8), I.D. 1/2 and O.D. 5/8 (length 2-3/4), and I.D. 1-1/8 and O.D. 1-1/8 (length 4-3/4).</p>	<p>Technical drawing of the Liquid pipe for model ARBLN14521. The main assembly has a total length of 17-1/2 inches and a height of 3-13/16 inches. It features a horizontal main pipe with a branch pipe. Dimensions include I.D. 5/8 for the main pipe, I.D. 3/4 for the branch pipe, and a total length of 16-3/8 inches for the main section. Details show pipes with O.D. 5/8 and I.D. 1/2 (length 4-3/8), O.D. 3/4 and I.D. 7/8 (length 3-3/16), and O.D. 1/2 and I.D. 3/8 (length 4-3/8).</p>

Indoor Unit Y-branches for Heat Recovery Operation

Unit: Inch

Models	Low-Pressure Vapor Pipe	Liquid pipe	High-Pressure Vapor Pipe
ARBLB01621			
ARBLB03321			
ARBLB07121			
ARBLB14521			

Outdoor Unit Product Data

Outdoor Unit Y-Branched

Outdoor Unit Y-branches for Heat Pump Operation

For Dual-Frame Systems

Unit: inch

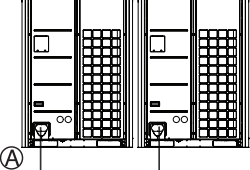
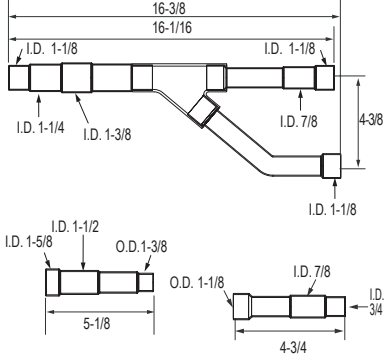
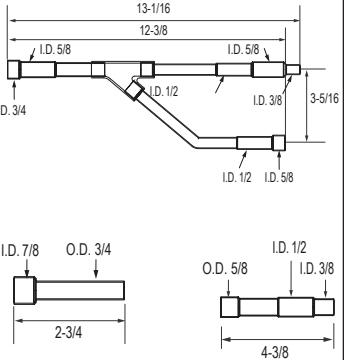
Combination	Multi-Frame Connector	Vapor pipe	Liquid pipe
	<p>Ⓐ</p> <p>ARCNN21</p>		

For Triple-Frame Systems

Unit: inch

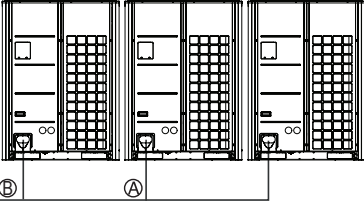
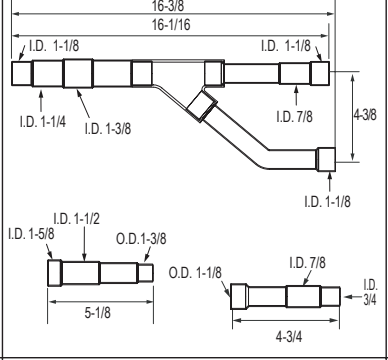
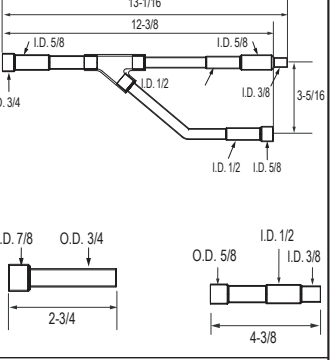
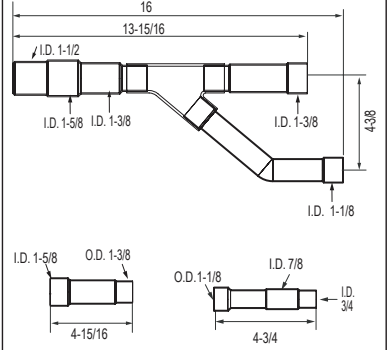
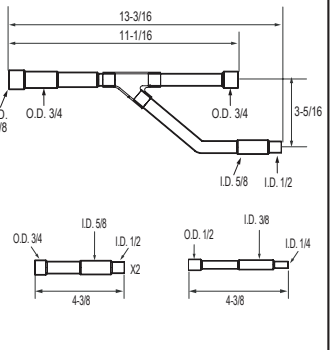
Combination specification	Multi-Frame Connector	Vapor pipe	Liquid pipe
	<p>Ⓐ</p> <p>ARCNN21</p>		
	<p>Ⓑ</p> <p>ARCNN31</p>		

Outdoor Unit Y-branches for Heat Recovery Operation

For Dual-Frame Systems

Unit: inch

Combination specification	Multi-Frame Connector	Low-Pressure Vapor Pipe	Liquid Pipe	High-Pressure Vapor Pipe
	<p>Ⓐ</p> <p>ARCNB21</p>			

For Triple-Frame Systems

Unit: inch

Combination specification	Multi-Frame Connector	Low-Pressure Vapor Pipe	Liquid Pipe	High-Pressure Vapor Pipe
	<p>Ⓐ</p> <p>ARCNB21</p>			
	<p>Ⓑ</p> <p>ARCNB31</p>			

Outdoor Unit Product Data

Headers

Headers for Heat Pump and Heat Recovery Operation

Unit: Inch

Models	Vapor pipe	Liquid pipe
4 branch ARBL054		
7 branch ARBL057		
4 branch ARBL104		
7 branch ARBL107		
10 branch ARBL1010		
10 branch ARBL2010		

Air Guides

(ZAGDKA52A)

Optional air guides are available for Multi V 5 outdoor units to change the discharge direction from vertical to horizontal.

Use ZAGDKA52A air guides with the following models:

6-ton to 20-ton Outdoor Units ARUM072CTE5, ARUM096CTE5, ARUM121CTE5, ARUM144CTE5, ARUM168CTE5, ARUM192CTE5, ARUM216CTE5, ARUM241CTE5.

Hail Guard Kits

(ZHGDKA52A)

Optional hail guard kits help protect the heat exchangers in Multi V 5 outdoor units.

Each kit includes:

- Right wind baffle
- Left wind baffle
- Rear wind baffle
- (50) #10 x 1/2 self-drilling hex head screws

Use ZHGDKA52A with the following Multi V 5 models:

6-ton to 20-ton Outdoor Units ARUM072CTE5, ARUM096CTE5, ARUM121CTE5, ARUM144CTE5, ARUM168CTE5, ARUM192CTE5, ARUM216CTE5, ARUM241CTE5.

Contact an LG Sales Representative to verify how many kits are needed for the dual and triple frame combination outdoor units.

Low Ambient Baffle Kits

(ZLABKA52A)

Optional low ambient baffle kits allow for Multi V 5 outdoor unit operation down to -9.9°F in cooling mode. When used with heat recovery operation, low ambient cooling to -9.9°F is possible only when all indoor units are operating in cooling mode. The low ambient wind baffle kit does not impact synchronous operating range.

Each kit includes:

- Right wind baffle
- Left wind baffle
- Rear wind baffle
- Top discharge elbow with motorized damper and 24V damper actuator
- (50) #10 x 1/2 self-drilling hex head screws
- Sealrite connector (for routing of actuator control and power wiring down to outdoor unit electrical box)
- PRVC2 Control kit is a required accessory (sold separately)

Use ZLABKA52A with the following Multi V 5 models:

6-ton to 20-ton Outdoor Units ARUM072CTE5, ARUM096CTE5, ARUM121CTE5, ARUM144CTE5, ARUM168CTE5, ARUM192CTE5, ARUM216CTE5, ARUM241CTE5.

Contact an LG Sales Representative to verify how many kits are needed for the dual and triple frame combination outdoor units.

LG Monitoring View (LGMV) Diagnostic Software and Cable

LGMV software allows the service technician or commissioning agent to connect a computer USB port to the outdoor unit main printed circuit board (PCB) using an accessory cable without the need for a separate interface device. The main screen for LGMV shall allow user to view the following real time data on one screen:

- Actual inverter compressor speed
- Target inverter compressor speed
- Actual outdoor fan speed
- Target outdoor unit fan speed
- Actual superheat
- Target superheat
- Actual subcooler circuit superheat
- Target subcooler circuit superheat
- Main EEV position
- Subcooling EEV position
- Inverter compressor current transducer value
- Outdoor air temperature
- Actual high pressure/saturation temperature
- Actual low pressure/saturation temperature
- Suction temperature
- Inverter compressor discharge temperature
- Constant speed compressor discharge temperature
- temperature
- Front outdoor coil pipe temperature
- Back outdoor coil pipe temperature
- Liquid line pipe temperature
- Subcooler inlet temperature
- Subcooler outlet temperature
- Average indoor unit (IDU) pipe temperature
- Inverter compressor operation indicator light
- Four-way reversing valve operation indicator light
- Pressure graph showing actual low pressure and actual high pressure levels
- Error code display
- Operating mode indicator
- Target high pressure
- Target low pressure
- PCB (printed circuit board) version
- Software version
- Installer name
- Model no. of outdoor units
- Site name
- Total number of connected indoor units
- Communication indicator lights
- Indoor unit capacity
- Indoor unit operating mode
- Indoor unit fan speed
- Indoor unit EEV position
- Indoor unit room temperature
- Indoor unit inlet pipe temperature
- Indoor unit outlet pipe temperature
- Indoor unit error code



Additional screens can be accessed by tabs on the main screen:

1. Cycleview: Graphic of internal components including:
 - Compressors showing actual speeds
 - EEVs
 - Indoor Units
 - Liquid injection valves
 - Temperature and pressure sensors
 - Four-way reversing valve
 - Outdoor fans showing status and speeds
2. Graph: Full screen graph of actual high and low pressures and high and low pressure limits. A sliding bar enables user to go back in time and view data.
3. Control IDU: Enables user to turn on all IDU's default setpoints of 86°F in heat mode or 64°F in cool mode.
4. Setting: Converts metric values to imperial values.
5. Making Data: Recording of real time data to a separate file created to be stored on the user's computer.
6. Loading Data: Recorded data from a saved ".CSV" file can be loaded to create an LGMV session.
7. Electrical Data: The lower half of main screen is changed to show the following:
 - Inverter compressor
 - Amps
 - Volts
 - Power Hz
 - Inverter control board fan Hz
 - Constant compressor
 - Current transducer value
 - Phase

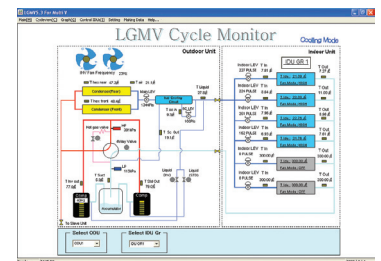

Figure 18: MV Cycleview.

In lieu of connecting to the outdoor unit, user has the option to connect to the indoor unit with the use of a USB to RS-485 connector kit. When connected through the indoor unit, user will not be able to record data.

This software can be used to both commission new systems and troubleshoot existing systems. LGMV data can be recorded to a ".CSV" file and emailed to an LG representative to assist with diagnostic evaluations.

Recommended Minimum PC Configuration:

- CPU: Pentium® IV 1.6 GHz
- Operating System: Windows® NT/2000/XP/Vista
- Main Memory: 256 MB
- Hard Disk: 600 MB when operating
- Web Browser: Internet Explorer® 5.0

LGMV is available in different formats, including Mobile LGMV, which is an app for use on wireless devices. Contact your LG Sales Representative for more information.

ELECTRICAL CONNECTIONS

System for Heat Pump Operation on page 64

System for Heat Recovery Operation on page 65

**DIP Switch Settings For Use With Gen 4 Indoor Units on
page 66**

SYSTEM FOR HEAT PUMP OPERATION, 575V

Figure 1: Example of a Typical Heat Pump Operation Power Wiring and Communications Cable Schematic.

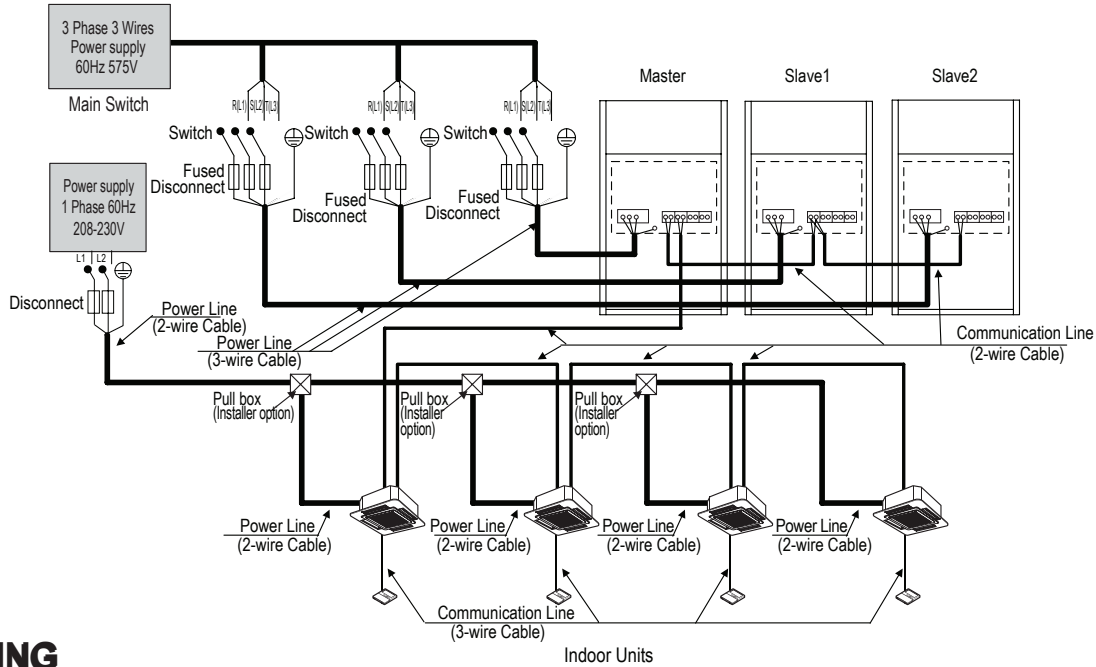

⚠ WARNING

- Ground wiring is required to prevent accidental electrical shock during current leakage, communication problems from electrical noise, and motor current leakage. ⚡ Do not connect the ground line to the pipes. There is risk of fire, electric shock, explosion, physical injury or death.
- Install a main shutoff switch that interrupts all power sources simultaneously. There is risk of fire, electric shock, explosion, physical injury or death. Communication cable between Master ODU to Slave ODU(s), and Master ODU to IDUs to be 18 AWG, 2-conductor, twisted, stranded, shielded. Ensure the communication cable shield is properly grounded to the Master ODU chassis only. ⚡ Do not ground the ODU to IDUs communication cable at any other point. Wiring must comply with all applicable local and national codes. Inadequate connections may generate heat, cause a fire, and physical injury or death.
- The GND terminal at the main PCB is a negative terminal for dry contact, not a ground. Inadequate connections may generate heat, cause a fire, and physical injury or death.

Heat Pump Operation

Communications Cable Between Master Outdoor Unit and Indoor Unit

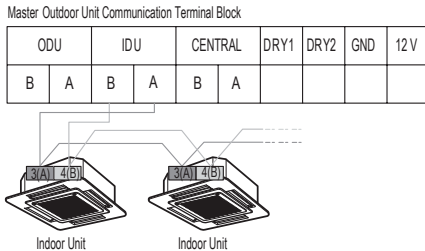

Communications Cable Between Master Outdoor Unit and Slave Outdoor Unit(s)

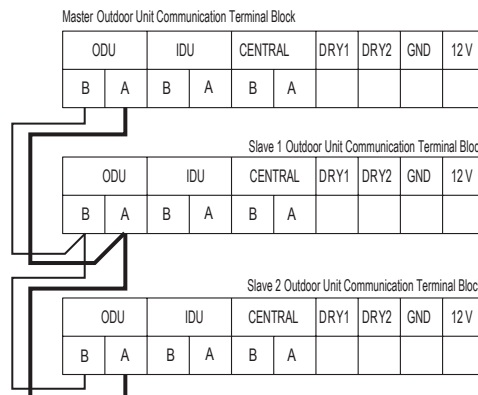

Note:

- Make sure that the terminal numbers of master outdoor unit and slave outdoor unit(s) match (A to A, B to B). The system will malfunction if not properly wired.
- Maintain polarity throughout the communication network. The system will malfunction if not properly wired.
- If the system operates in reversed phase, it may break the compressors and other components.
- If there is a possibility of reversed phase, phase loss, momentary blackout, or the power goes on and off while the system is operating, install a field-supplied phase loss protection circuit. Operating the system in reverse phase may break the compressor and other unit components.

Figure 2: Example of a Typical Heat Recovery Operation Power Wiring and Communications Cable Schematic.

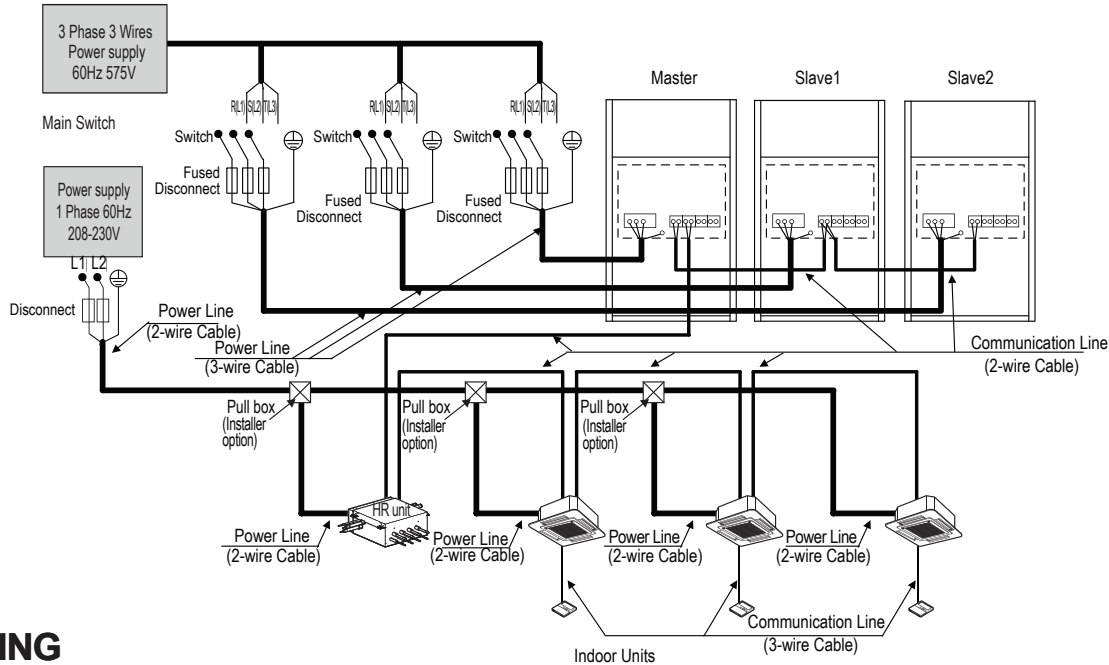

⚠ WARNING

- Ground wiring is required to prevent accidental electrical shock during current leakage, communication problems from electrical noise, and motor current leakage. ⚡ Do not connect the ground line to the pipes. There is risk of fire, electric shock, explosion, physical injury or death.
- Install a main shutoff switch that interrupts all power sources simultaneously. There is risk of fire, electric shock, explosion, physical injury or death.
- Communication cable between Master ODU to Slave ODU(s), and Master ODU to IDUs / HRUs to be 18 AWG, 2-conductor, twisted, stranded, shielded. Ensure the communication cable shield is properly grounded to the Master ODU chassis only. ⚡ Do not ground the ODU to IDUs / HRUs communication cable at any other point. Wiring must comply with all applicable local and national codes. Inadequate connections may generate heat, cause a fire, and physical injury or death.
- The GND terminal at the main PCB is a negative terminal for dry contact, not a ground. Inadequate connections may generate heat, cause a fire, and physical injury or death.

Heat Recovery Operation

Communications Cable Between Master Outdoor Unit and Heat Recovery Units / Indoor Units

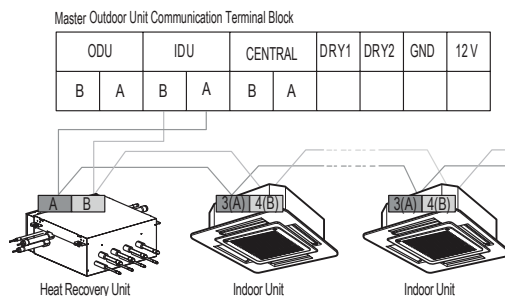

Communications Cable Between Master Outdoor Unit and Slave Outdoor Unit(s)

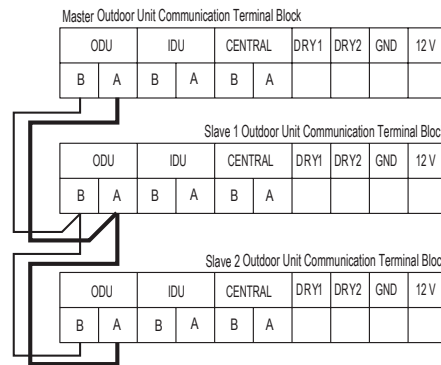

Note:

- Make sure that the terminal numbers of master outdoor unit and slave outdoor unit(s) match (A to A, B to B). The system will malfunction if not properly wired.
- Maintain polarity throughout the communication network. The system will malfunction if not properly wired.
- If the system operates in reversed phase, it may break the compressors and other components.
- If there is a possibility of reversed phase, phase loss, momentary blackout, or the power goes on and off while the system is operating, install a field-supplied phase loss protection circuit. Operating the system in reverse phase may break the compressor and other unit components.



Due to our policy of continuous product innovation, some specifications may change without notification.

DIP SWITCH SETTINGS FOR USE WITH GEN 4 INDOOR UNITS

Generation 4 Equipment

The latest versions of LG's indoor units are designated Generation 4 (Gen 4). For Gen 4 indoor units to operate with Gen 4 indoor unit features, the air conditioning system must meet the following requirements:

- All indoor units, heat recovery units, and air / water source units must be Gen 4 or higher.
- All air / water source units must have Gen 4 or higher software installed.
- Air / water source units DIP switch 3 must be set to ON (factory default setting is OFF).
- All controllers must support Gen 4 indoor unit features.

Figure 3: Location and Setting of Outdoor Unit DIP Switch 3.

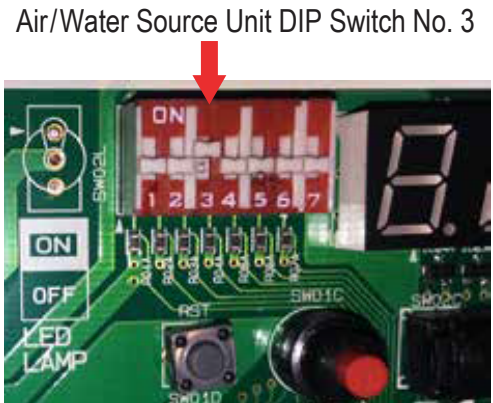

The figure at right shows the outdoor unit DIP switch. The "System Component Combinations and Operation Status" table lists how combining different components will affect system operation. The "Serial Numbers or Air / Water Source Units with Gen 4 or Higher Software" table lists the serial numbers of air and water source units that have Gen 4 or higher software. All air and water source units, indoor units, heat recovery units, and controllers in a system must be Gen 4 compatible or the system will not operate with Gen 4 indoor unit features.

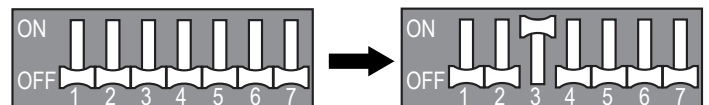

Table 1: System Component Combinations and Operation Status.

Air / Water Source Units*	Indoor Unit(s)**	Heat Recovery Unit(s)	Outdoor Unit DIP Switch No. 3	Operation Status
Gen 4 or Higher	Gen 4 ONLY	Model 2A ONLY	Must be ON	System will operate WITH Gen. 4 indoor unit features.
Gen 4 or Higher	Gen 4 ONLY	Model 2A ONLY	OFF	System will operate but WITHOUT Gen. 4 indoor unit features.
Gen 4 or Higher	Gen 4 ONLY	Any combination of Models 1A, 2A	Must be OFF (factory default)	Does NOT include Gen. 4 features. System will not operate if DIP Switch No. 3 is ON, and an error code will be generated.
Gen 4 or Higher	Any combination of Gen 2 and Gen 4	Model 2A ONLY	Must be OFF (factory default)	
Gen 4 or Higher	Any combination of Gen 2 and Gen 4	Any combination of Models 1A, 2A	Must be OFF (factory default)	
Gen 2	Any combination of Gen 2 and Gen 4	Any combination of Models 0A****, 1A, 2A	N/A***	Does not include Gen. 4 features.

*Gen 4 or Higher Air / Water Source Units = Multi V 5, Multi V IV or Multi V Water IV with Gen 4 or Higher software (see table below for Gen 4 or higher serial numbers) or Multi V S.

Gen 2 Air / Water Source Units = Multi V II, Multi V III, Multi V IV without Gen. 4 software, Multi V Water II, Multi V Water IV without Gen. 4 software, Multi V Mini, Multi V Water Mini, or Multi V Space II.

**Gen 4 Indoor Units model numbers end in "4"; Gen 2 Indoor Units model numbers end in "2" or an "A", including Hydro Kit.

***DIP Switch No. 3 on Gen 2 air / water source units is not related to Gen 4 features as it is with Gen 4 air / water source units.

****0A Model Heat Recovery units are not for use with Multi V 5, Multi V IV, Multi V Water IV, or Multi V III heat recovery systems.

Table 2: Serial Numbers of Air / Water Source Units with Gen 4 or Higher Software.

Air / Water Source Unit Model Type	Multi V Air Source Heat Pump	Multi V Air Source Heat Recovery	Multi V IV Water Source Heat Pump	Multi V IV Water Source Heat Recovery
Serial Number of Air / Water Source Units with Gen 4 or Higher Software	502***** and Higher	503***** and Higher	504***** and Higher	

PIPING LIMITATIONS AND PLACEMENT CONSIDERATIONS

Piping Limitations on page 68

**Refrigerant Piping for Separated Outdoor Units on
page 74**

**Selecting the Best Location for Outdoor Unit(s) on
page 77**

Outdoor Unit Clearance Requirements on page 79

Installing Outdoor Units Indoors on page 80

PIPING LIMITATIONS

For Systems Designed for Heat Pump Operation

Following pages present Multi V 5 piping limitations and are for illustrative purposes only. Designers MUST use LATS when designing LG VRF systems.

Figure 1: Typical Heat Pump System Building Layout with Piping Limitations.

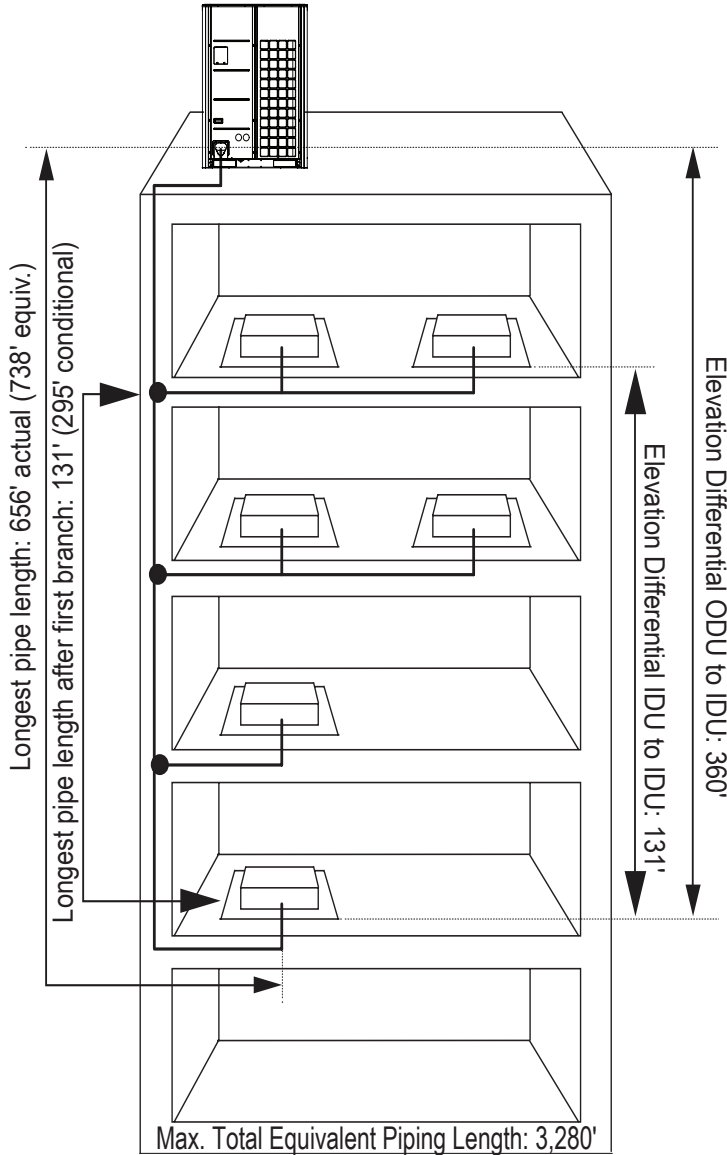

MULTI V 5 Outdoor Unit Engineering Manual

Table 1: Piping Limitations for Heat Pump Operation (See next page).

Length	Total pipe length $A + \Sigma B + \Sigma C \leq 3,280$ feet	Longest actual pipe length ≤ 492 feet (656 feet conditional application)	Equivalent pipe length ¹ ≤ 574 feet (738 feet conditional application)
l	Longest pipe length after first branch ≤ 131 feet (295 feet conditional application)		
Elevation1	Elevation differential (Outdoor Unit ↔ Indoor Unit) Height ≤ 360 feet		
Elevation2	Elevation differential (Indoor Unit ↔ Indoor Unit) height ≤ 131 feet		
height1	Elevation differential (Outdoor Unit ↔ Outdoor Unit) 16.4 feet		
	Distance between Outdoor Unit to Outdoor Unit	≤ 33 feet (Max. 43 feet for ODU ≥ 12 tons)	
	Distance between fittings and Indoor Unit	≥ 20 inches	
	Distance between fittings and Y-branches / Headers	≥ 20 inches	
	Distance between two Y-branches / Headers	≥ 20 inches	

¹Assume equivalent pipe length of Y-branch is 1.6 feet, and equivalent pipe length of header is 3.3 feet.

Following pages present Multi V 5 piping limitations and are for illustrative purposes only. Designers MUST use LATS when designing LG VRF systems.

Example of Pipe Sizing When Installing a Heat Pump System

Example: Five (5) indoor Units Connected

ODU: Outdoor Units.

IDU: Indoor Units.

A: Main Pipe from Outdoor Unit to Y-branch.

B: Y-branch to Y-branch.

C: Y-branch to Indoor Unit.

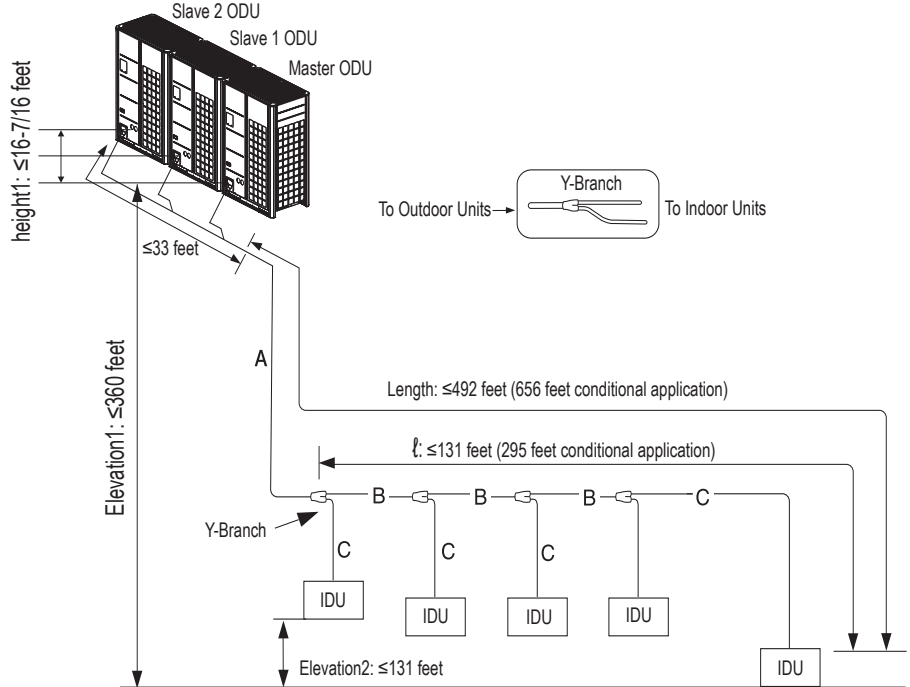

Note:

- Always reference the LATS HVAC software report.
- Larger-capacity outdoor units must be the master in a multi-frame system.
- Master outdoor unit capacity must be greater than or equal to the slave1 outdoor unit capacity, and, where applicable, slave1 outdoor unit capacity must be greater than or equal to the slave2 outdoor unit capacity.
- Connection piping from branch to branch cannot exceed the main pipe diameter (A) used by the outdoor unit.
- Install the header branches so that the pipe distances between the connected indoor units are minimized. Large differences in pipe distances can cause indoor unit performances to fluctuate.
- Y-branches and other header branches cannot be installed downstream of the initial header branch.

Table 2: Main Pipe (A) Diameters from Outdoor Unit to First Y-branch / Header Branch.

ODU Capacity (ton)	Pipe diameter when pipe length is <295 feet (Standard)		Pipe diameter when pipe length is ≥295 feet (ODU ↔ IDU)		Pipe diameter when height differential (ODU ↔ IDU) is >164 feet	
	Liquid pipe (inches OD)	Vapor pipe (inches OD)	Liquid pipe (inches OD)	Vapor pipe (inches OD)	Liquid pipe (inches OD)	Vapor pipe (inches OD)
6	3/8Ø	3/4Ø	1/2Ø	7/8Ø	1/2Ø	No Increase
8	3/8Ø	7/8Ø	1/2Ø	1-1/8Ø	1/2Ø	No Increase
10-12	1/2Ø	1-1/8Ø	5/8Ø	No Increase	5/8Ø	No Increase
14-18	5/8Ø	1-1/8Ø	3/4Ø	1-1/4Ø	3/4Ø	No Increase
20	5/8Ø	1-3/8Ø	3/4Ø	No Increase	3/4Ø	No Increase
22-28	3/4Ø	1-3/8Ø	7/8Ø	1-1/2Ø	7/8Ø	No Increase
30-42	3/4Ø	1-5/8Ø	7/8Ø	No Increase	7/8Ø	No Increase

PIPING LIMITATIONS

For Systems Designed for Heat Pump Operation

Following pages present Multi V 5 piping limitations and are for illustrative purposes only. Designers MUST use LATS when designing LG VRF systems.

Table 3: Pipe Diameters (B) from Y-branch to Y-branch / Header.

Downstream Total Capacity of IDUs (Btu/h)	Liquid pipe (inches OD)	Vapor pipe (inches OD)
≤19,100	1/4Ø	1/2Ø
≤54,600	3/8Ø	5/8Ø
≤76,400	3/8Ø	3/4Ø
≤114,700	3/8Ø	7/8Ø
≤172,000	1/2Ø	1-1/8Ø
≤229,300	5/8Ø	1-1/8Ø
≤248,400	5/8Ø	1-3/8Ø
≤344,000	3/4Ø	1-3/8Ø
≤592,500	3/4Ø	1-5/8Ø

¹For the first branch pipe, use the branch pipe that matches main pipe A diameter.

Table 4: Indoor Unit Connecting Pipe from Branch (C).

Indoor Unit Capacity ¹	Liquid pipe (inches OD)	Vapor pipe (inches OD)
≤19,100	1/4Ø	1/2Ø
≤54,600	3/8Ø	5/8Ø
≤76,400	3/8Ø	3/4Ø
≤95,900	3/8Ø	7/8Ø

¹9,600-24,200 Btu/h 4-way 3 feet x 3 feet Cassette and 15,400-24,200 Btu/h High Static Ducted indoor units have 3/8Ø (liquid) and 5/8Ø (vapor).

Conditional Applications

Conditional applications are computed in LATS. See below for an explanation of when pipes are upsized.

If the equivalent length between the first Y-branch to the farthest indoor unit is >131 feet (up to 295 feet maximum):

- Pipe segment diameters between the first Y-branch and the second Y-branch must be sized up by one. This applies to both liquid and vapor pipes. If the next size up is not available, or if the piping segment diameters are the same as main pipe (A) diameters, sizing up is not possible.
- While calculating the entire refrigerant pipe length, pipe lengths for ΣB must be multiplied by two: $A + (\Sigma B \times 2) + \Sigma C \leq 3,281$ feet.
- Length of pipe (C) from each indoor unit to the closest Y-branch or header ≤ 131 ft.
- $[\text{Length of pipe from outdoor unit to farthest indoor unit (A+B+C)}] - [\text{Length of pipe from outdoor unit to closest indoor unit (A+B+C)}] \leq 131$ feet.

If the pipe (B) diameters after the first branch are bigger than the main pipe (A) diameters, pipe (B) must be changed to match main pipe (A) sizes.

Example: When an indoor unit combination ratio of 120% is connected to a 22-ton outdoor unit:

Outdoor unit main pipe (A) diameters: 1-3/8Ø inches (vapor) and 5/8Ø inches (liquid).

1. Pipe (B) diameters: 1-3/8Ø (vapor) and 3/4Ø (liquid) (after the first branch, when indoor unit combination ratio is 120% [26 tons]).
2. After the first branch, pipe (B) diameters must be changed to 1-3/8Ø inches (vapor) and 5/8Ø inches (liquid) to match main pipe (A) sizes.

Instead of using the total indoor unit capacity to choose main pipe (A) diameters, use outdoor unit capacity to choose downstream main pipe (A) diameters. ⚠ Do not permit connection pipes (B) from branch to branch to exceed main pipe (A) diameters as indicated by outdoor unit capacity. Example: When an indoor unit combination ratio of 120% is connected to a 20-ton outdoor unit (24 tons), and indoor unit with a 7,000 Btu/h capacity is located at the first branch:

1. Main pipe (A) diameters on a 20-ton outdoor unit: 1-1/8Ø inches (vapor) and 5/8Ø inches (liquid).
2. Pipe diameters between first and second branches, however, are: 1-3/8Ø (vapor) and 3/4Ø (liquid) (connected downstream indoor unit capacity is 20 tons).
3. If main pipe (A) diameters of a 20-ton outdoor unit are 1-1/8Ø (vapor) and 5/8Ø (liquid), then the pipe diameters between the first and second branches must be changed to match.

For Systems Designed for Heat Recovery Operation

Following pages present Multi V 5 piping limitations and are for illustrative purposes only. Designers MUST use LATS when designing LG VRF systems.

Figure 2: Typical Heat Recovery System Building Layout with Piping Limitations.

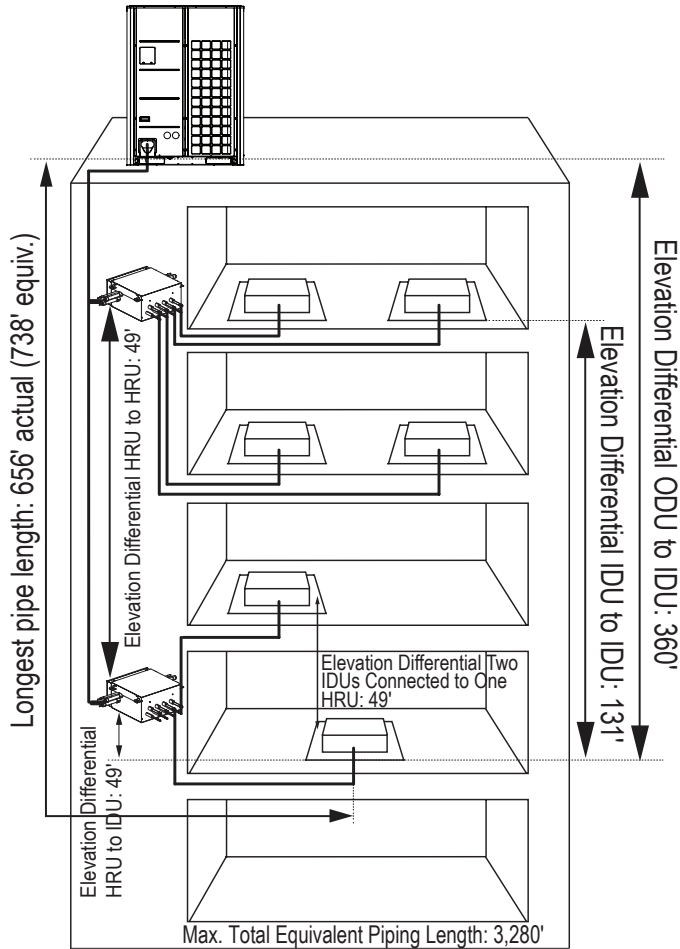

Piping Limitations and Placement Considerations

Table 5: Piping Limitations for Heat Recovery Operation (See next page).

Length	Total pipe length $A + \Sigma B + \Sigma C \leq 3,280$ feet	Longest actual pipe length ≤ 492 feet (656 feet conditional application)	Equivalent pipe length ¹ ≤ 574 feet (738 feet conditional application)
ℓ	Longest pipe length after first branch ≤ 131 feet (295 feet conditional application)		
Elevation1	Elevation differential (Outdoor Unit ↔ Indoor Unit) Height ≤ 360 feet		
Elevation2	Elevation differential (Indoor Unit ↔ Indoor Unit) height ≤ 131 feet		
Elevation3	Elevation differential (Indoor Unit ↔ Heat Recovery Unit) [single heat recovery unit or series heat recovery units] 49 feet		
Elevation4	Elevation differential (Indoor Unit ↔ Indoor Unit [connected to same Heat Recovery Unit]) 49 feet		
height1	Elevation differential (Outdoor Unit ↔ Outdoor Unit) ≤ 16.4 feet		
Distance between Outdoor Unit to Outdoor Unit		≤ 33 feet (Max. 43 feet for Outdoor Unit ≥ 12 tons)	
Distance between fittings and Indoor Unit		≥ 20 inches	
Distance between fittings and Y-branches / Headers		≥ 20 inches	
Distance between two Y-branches / Headers		≥ 20 inches	
Height differential between two Heat Recovery Units if installed with a Y-branch		≤ 49 feet	
Height differential between two series-piped Heat Recovery Units		≤ 16 feet	

¹Assume equivalent pipe length of Y-branch is 1.6 feet, and equivalent pipe length of header is 3.3 feet.

PIPING LIMITATIONS

For Systems Designed for Heat Recovery Operation

Following pages present Multi V 5 piping limitations and are for illustrative purposes only. Designers MUST use LATS when designing LG VRF systems.

Example of Pipe Sizing When Installing a Heat Recovery System

Example: Triple-frame system, four (4) heat recovery units, one (1) header, and twelve (12) indoor units connected

ODU: Outdoor Units.

HRU: Heat Recovery Units.

IDU: Indoor units.

A: Main Pipe from Outdoor Unit to First Y-branch.

B: Heat Recovery Unit to Heat Recovery Unit, Y-branch to Heat Recovery Unit, Heat Recovery Unit to Header, or Y-branch to Y-branch.

C: Heat Recovery Unit / Header to Indoor Unit.

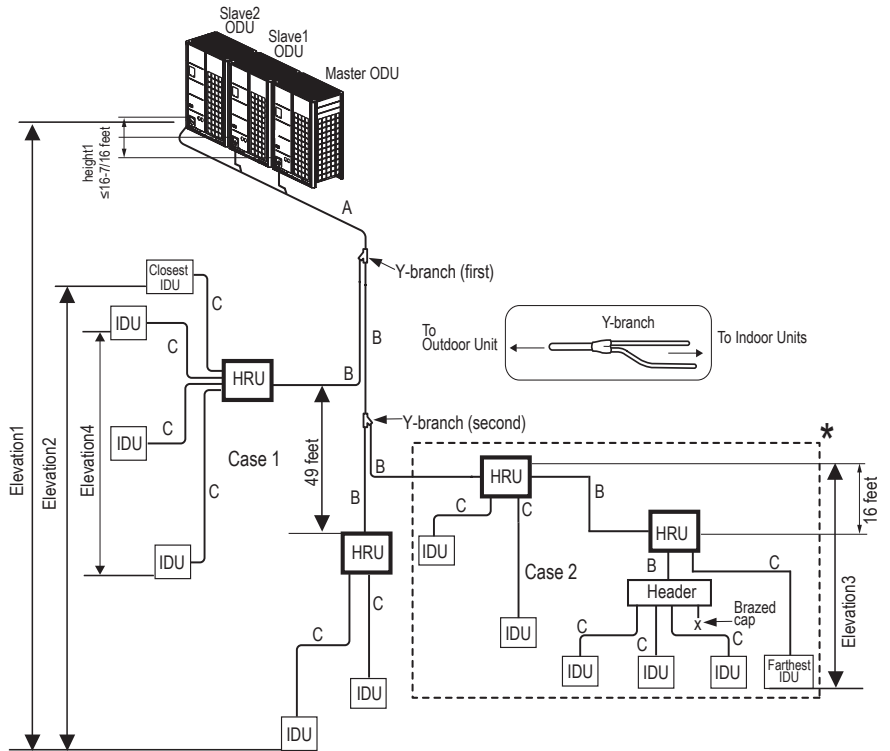

Case 1: Maximum height is 131 feet if installed with a Y-branch.
Case 2: Maximum height is 16 feet in heat recovery control unit series connection.

Note:

- Always reference the LATS HVAC software report.
- Larger-capacity outdoor units must be the master in a multi-frame system.
- Master outdoor unit capacity must be greater than or equal to the slave1 outdoor unit capacity, and, where applicable, slave1 outdoor unit capacity must be greater than or equal to the slave2 outdoor unit capacity.
- Connection piping from branch to branch cannot exceed the main pipe diameter (A) used by the outdoor unit.
- Install the header branches or heat recovery units so that the pipe distances between the connected indoor units are minimized. Large differences in pipe distances can cause indoor unit performances to fluctuate.
- Y-branches and other header branches cannot be installed downstream of the initial header branch.
- Total capacity of indoor units in series connection of heat recovery units $\leq 192,400$ Btu/h.
- If large capacity indoor units ($>12,000$ Btu/h with piping sizes $>5/8\text{Ø}$ / $3/8\text{Ø}$) are installed, the valve group setting must be used. (Refer to the PCB of the heat recovery unit for the valve group control setting.)

Table 6: Main Pipe (A) Diameters from Outdoor Unit to First Y-branch.

ODU Capacity (ton)	Standard Pipe Diameter			Pipe diameter when pipe length is ≥ 295 feet or when height differential (ODU \leftrightarrow IDU) is >164 feet		
	Liquid Pipe (inches OD)	Low Pressure Vapor Pipe (inches OD)	High Pressure Vapor Pipe (inches OD)	Liquid Pipe (inches OD)	Low Pressure Vapor Pipe (inches OD)	High Pressure Vapor Pipe (inches OD)
6	3/8Ø	3/4Ø	5/8Ø	1/2Ø	No Increase	No Increase
8	3/8Ø	7/8Ø	3/4Ø	1/2Ø	No Increase	No Increase
10	1/2Ø	1-1/8Ø	3/4Ø	5/8Ø	No Increase	No Increase
12	1/2Ø	1-1/8Ø	7/8Ø	5/8Ø	No Increase	No Increase
14-16	5/8Ø	1-1/8Ø	7/8Ø	3/4Ø	No Increase	No Increase
18-20	5/8Ø	1-3/8Ø	1-1/8Ø	3/4Ø	No Increase	No Increase
22-28	3/4Ø	1-3/8Ø	1-1/8Ø	7/8Ø	No Increase	No Increase
30-42	3/4Ø	1-5/8Ø	1-1/8Ø	7/8Ø	No Increase	No Increase

For Systems Designed for Heat Recovery Operation

Following pages present Multi V 5 piping limitations and are for illustrative purposes only. Designers MUST use LATS when designing LG VRF systems.

Table 7: Refrigerant Pipe (B) Diameters between Y-branches and Y-branches / Heat Recovery Unit / Headers.

Downstream IDU total capacity (Btu/h)	Liquid pipe (inches OD)	Vapor pipe (inches OD)	
		Low pressure	High pressure
≤19,100	1/4Ø	1/2Ø	3/8Ø
≤54,600	3/8Ø	5/8Ø	1/2Ø
≤76,400	3/8Ø	3/4Ø	5/8Ø
≤114,700	3/8Ø	7/8Ø	3/4Ø
≤172,000	1/2Ø	1-1/8Ø	7/8Ø
≤229,300	5/8Ø	1-1/8Ø	7/8Ø
≤248,400	5/8Ø	1-3/8Ø	1-1/8Ø
≤344,000	3/4Ø	1-3/8Ø	1-1/8Ø
≤592,500	3/4Ø	1-5/8Ø	1-3/8Ø

Table 8: Indoor Unit Connecting Pipe from Branch (C).

Indoor Unit Capacity ¹	Liquid pipe (inches OD)	Vapor pipe (inches OD)
≤19,100	1/4Ø	1/2Ø
≤54,600	3/8Ø	5/8Ø
≤76,400	3/8Ø	3/4Ø
≤95,900	3/8Ø	7/8Ø

¹9,600-24,200 Btu/h 4-way 3 feet x 3 feet Cassette and 15,400-24,200 Btu/h High Static Ducted IDUs have 3/8Ø (liquid) and 5/8Ø (vapor).

Conditional Applications

Conditional applications are computed in LATS. See below for an explanation of when pipes are upsized.

If the equivalent length between the first Y-branch to the farthest indoor unit is >131 feet (maximum 295 feet):

- Pipe segment diameters between the first branch and the last branch must be sized up by one. This applies to both liquid and low / high vapor pipes. If the next size up is not available, or if the pipe segment diameters are the same as main pipe (A) diameters, sizing up is not possible.
- While calculating total refrigerant piping length, pipe (B) segment lengths between the first Y-branch and second Y-branch, and between the second Y-branch and the heat recovery unit must be calculated by two.
- Length of pipe (C) from each indoor unit to the closest Y-branch, header, or heat recovery unit ≤49 feet.
- [Length of pipe from outdoor unit to farthest indoor unit (A+B+C)] - [Length of pipe from outdoor unit to closest indoor unit (A+B+C)] ≤131 feet.

REFRIGERANT PIPING FOR SEPARATED OUTDOOR UNITS

Dual-frame and triple-frame systems should be installed with all outdoor units located next to each other. In conditions where the dual-frame or triple-frame outdoor units need to be separated, the following rules must be followed:

1. Measurements.

All measurements should be made from the union center of the outdoor unit Y-branch.

Figure 3: Y-branch Measurement Location.

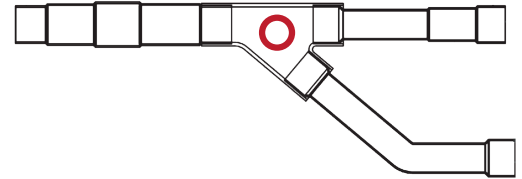

2. Maximum pipe length from first outdoor unit Y-branch to farthest outdoor unit. Total pipe length from the first outdoor unit Y-branch to the piping connection at the farthest outdoor unit must not exceed thirty-three (33) feet.

Figure 4: Maximum Pipe Length from First Outdoor Unit Y-branch to Farthest Outdoor Unit.

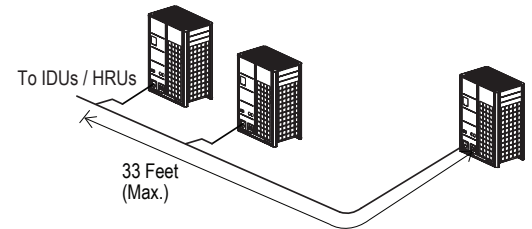

3. Elevation difference between outdoor units. The elevation difference between the highest and lowest elevation outdoor unit must not exceed sixteen (16) feet.

Figure 5: Elevation Difference Between Outdoor Units.

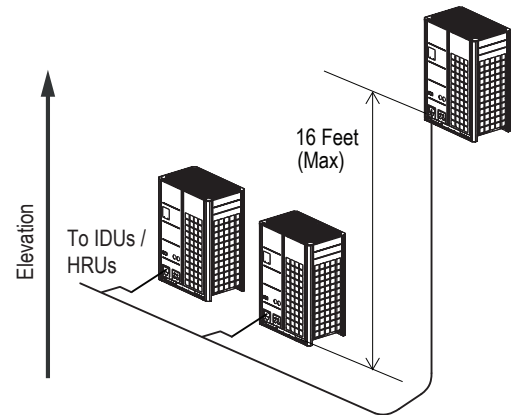

Trapping

1. When required, all traps must be inverted type traps $\geq 8"$ in the vapor line(s).
 - a. Heat pump outdoor units would be trapped in the suction vapor line, and heat recovery outdoor units would be trapped in the high AND low pressure vapor lines.
 - b. Inverted traps are defined as any piping that is $\geq 8"$ in a vertical direction up the horizontal pipe it elevates from.

Figure 6: Traps for Heat Pump and Heat Recovery Systems.

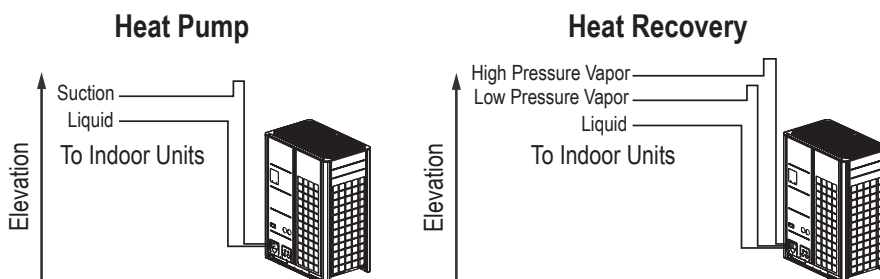

Figure 7: Close Up of An Inverted Oil Trap.



1. Inverted traps are required when:

- a. Piping in a horizontal direction from the outdoor Y-branch towards an outdoor unit or another outdoor unit Y-branch is greater than 6.6'. The inverted trap should be installed close to the outdoor unit Y-branch (no more than 6.6' away).
- b. Anytime piping turns downward leaving an outdoor unit Y-branch toward an outdoor unit or another outdoor unit Y-branch. The inverted trap should be installed close to the outdoor unit Y-branch (no more than 6.6' away), and before the pipe toward the outdoor unit turns downward.

Figure 8: Examples of Inverted Traps.

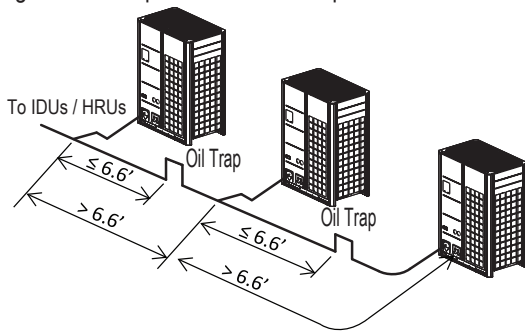
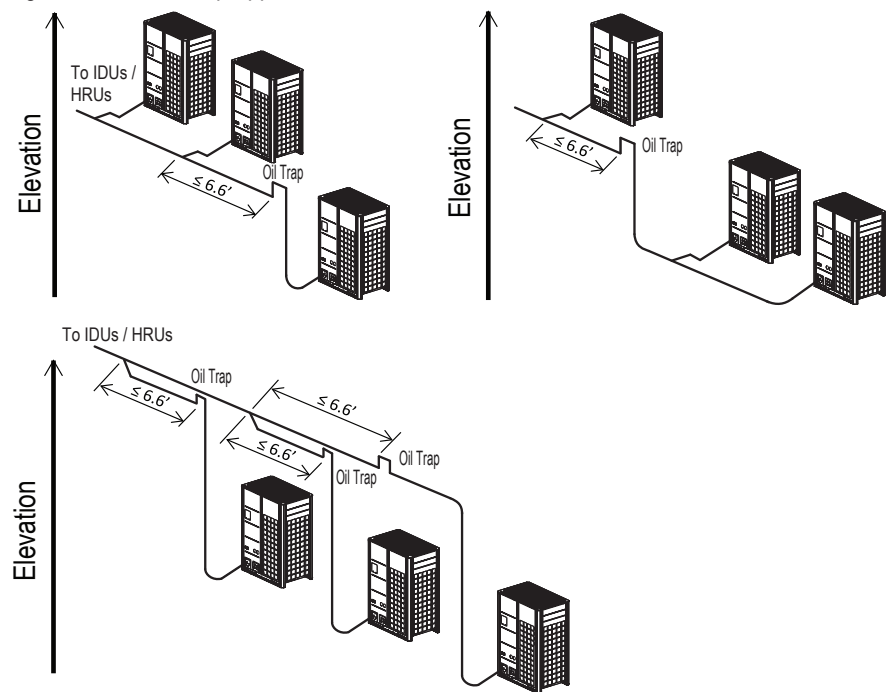

Figure 9: Inverted Trap Applications.



Pipe Slope

Horizontal pipe slope should be level or slightly away from the outdoor units, otherwise refrigerant and oil will migrate toward the outdoor units and accumulate in the pipe segment serving the frame that is not running or at the lowest elevation. Piping should never slope more than -10° (see figure) without installing an inverted trap within 6.6' of the outdoor unit Y-branch and before the pipe slopes downward toward the outdoor unit.

Figure 10: Allowable Pipe Slope.

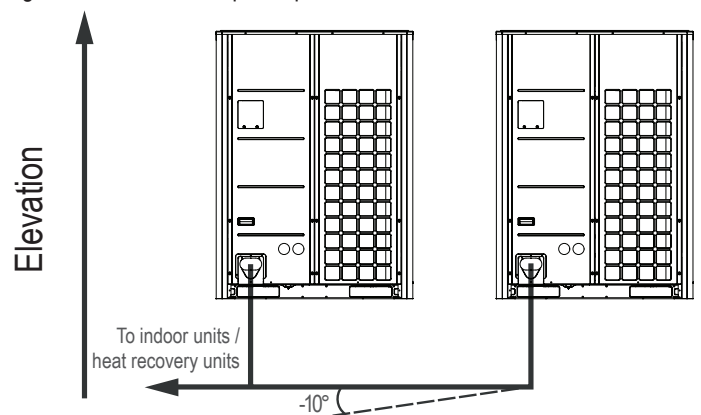

REFRIGERANT PIPING FOR SEPARATED OUTDOOR UNITS

MULTI V™ 5

Height Differential for Separated Outdoor Units

Maximum allowable height differential (h) between two outdoor units is 16.4 feet.

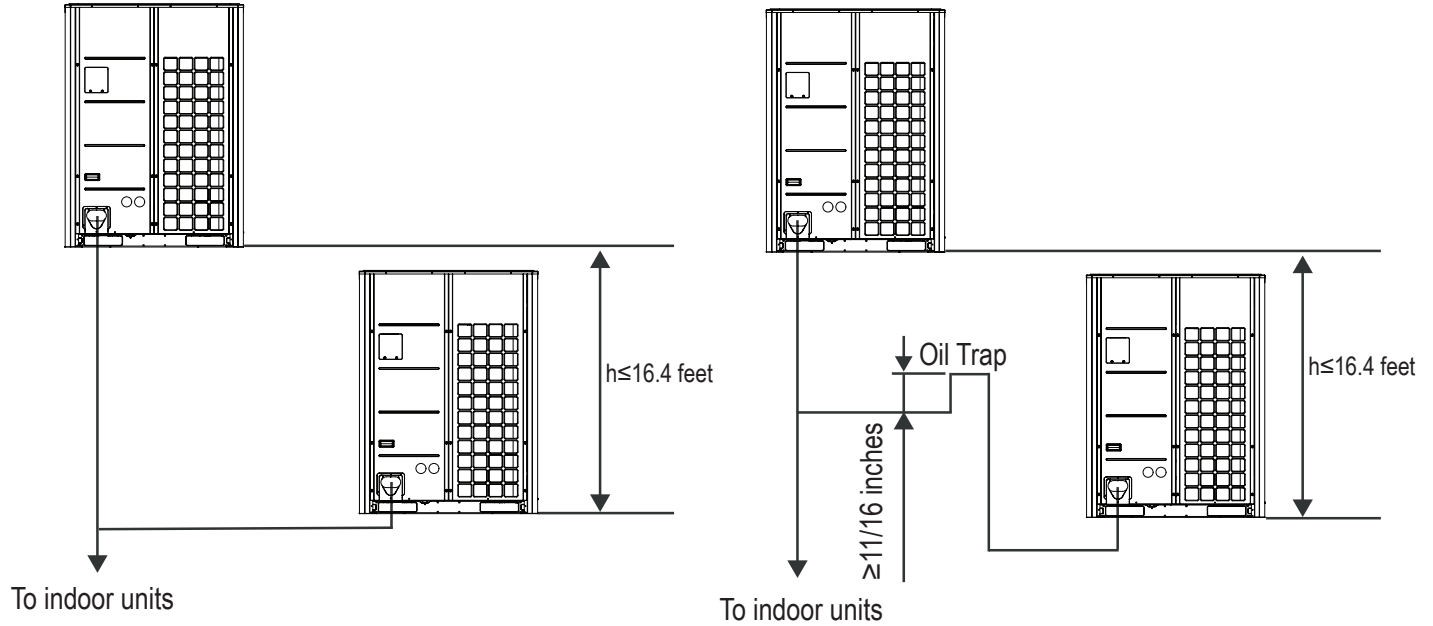

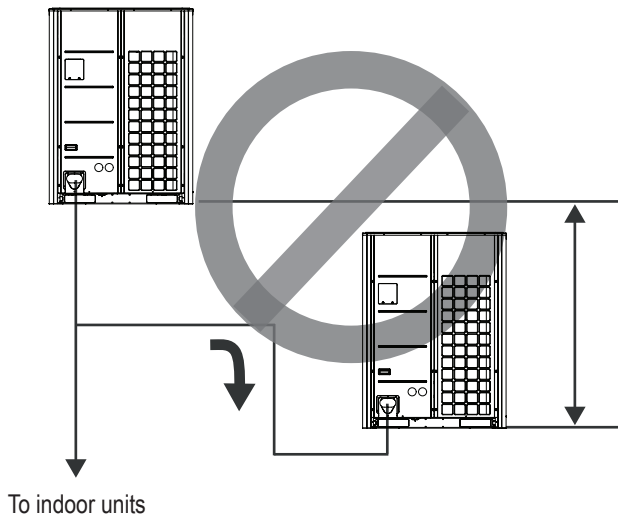

Example of an Incorrect Height Differential



Selecting the Best Location for the Outdoor Unit(s)

⚠ DANGER

-  Do not install the unit in an area where combustible gas may generate, flow, stagnate, or leak. These conditions can cause a fire, resulting in bodily injury or death.
-  Do not install the unit in a location where acidic solution and spray (sulfur) are often used as it can cause bodily injury or death.
-  Do not use the unit in environments where oil, steam, or sulfuric gas are present as it can cause bodily injury or death.

⚠ CAUTION

When deciding on a location to place the outdoor unit, be sure to choose an area where run-off from defrost will not accumulate and freeze on sidewalks or driveways, which may create unsafe conditions. Properly install and insulate any drain hoses to prevent the hose from freezing, cracking, leaking, and causing unsafe conditions from frozen condensate.

⚠ WARNING

Install a fence to prevent vermin from crawling into the unit or unauthorized individuals from accessing it.

Select a location for installing the outdoor unit that will meet the following conditions:

- Where there is enough strength to bear the weight of the outdoor unit.
- A location that allows for optimum air flow and is easily accessible for inspection, maintenance, and service.
- Where piping between the outdoor unit and indoor unit(s) / heat recovery units are within allowable limits.
- Include space for drainage to ensure condensate flows properly out of the unit when it is in heating mode. Avoid placing the outdoor unit in a low-lying area where water could accumulate.
- If the outdoor unit is installed in a highly humid environment (near an ocean, lake, etc.), ensure that the site is well-ventilated and has a lot of natural light (Example: Install on a rooftop).

 **Don'ts**

- Where it will be subjected to direct thermal radiation from other heat sources, or an area that would expose the outdoor unit to heat or steam like discharge from boiler stacks, chimneys, steam relief ports, other air conditioning units, kitchen vents, plumbing vents, and other sources of extreme temperatures.
- Where high-frequency electrical noise / electromagnetic waves will not affect operation.
- Where operating sound from the unit will disturb inhabitants of surrounding buildings.
- Where the unit will be exposed to direct, strong winds.
- Where the discharge of one outdoor unit will blow into the inlet side of an adjacent unit (when installing multiple outdoor units).

Planning for Snow and Ice

To ensure the outdoor unit operates properly, certain measures are required in locations where there is a possibility of heavy snowfall or severe windchill or cold:

1. Prepare for severe winter wind chills and heavy snowfall, even in areas of the country where these are unusual phenomena.
2. Position the outdoor unit so that its airflow fans are not buried by direct, heavy snowfall. If snow piles up and blocks the airflow, the system may malfunction.
3. Remove any snow that has accumulated four (4) inches or more on the top of the outdoor unit.
4. In climates that may experience significant snow buildup, mount the outdoor unit on a raised, field-provided platform or stand. The raised support platform must be high enough to allow the unit to remain above possible snow drifts, and must be higher than the maximum anticipated snowfall for the location.
5. Design the mounting base to prevent snow accumulation on the platform in front or back of the unit frame.
6. Provide a field fabricated snow protection hood to keep snow and ice and/or drifting snow from accumulating on the coil surfaces.
7. Install a hail guard kit and air guide accessories (sold separately) to prevent snow or rain from accumulating on the fan inlet / outlet guards.
8. Consider tie-down requirements in case of high winds or where required by local codes.

⚠ CAUTION

When deciding on a location to place the outdoor unit, be sure to choose an area where run-off from defrost will not accumulate and freeze on sidewalks or driveways, which may create unsafe conditions. Properly install and insulate any drain hoses to prevent the hose from freezing, cracking, leaking, and causing unsafe conditions from frozen condensate.

Selecting the Best Location for the Outdoor Unit(s)

Planning for Snow and Ice, continued.

Note:

Choose an area where run-off from defrost mode will not accumulate and freeze on sidewalks or driveways. Properly install and insulate any drain hoses to prevent the hose from freezing, cracking, leaking, and damaging the outdoor unit.

Note:

The system may take longer to provide heat, or heating performance will be reduced in winter if the outdoor unit is installed:

1. In a narrow, shady location.
2. Near a location that has a lot of ground moisture.
3. In a highly humid environment.
4. In an area in which condensate does not drain properly.

Tie-Downs and Wind Restraints

The strength of Multi V frames is adequate to be used with field-provided wind restraint tie-downs. The overall tie-down configuration must be approved by a local professional engineer. Always refer to local code when designing a wind restraint system.

Oceanside Installation Precautions

Note:

Ocean winds may cause corrosion, particularly on the condenser and evaporator fins, which, in turn could cause product malfunction or inefficient performance.

- Avoid installing the outdoor unit where it would be directly exposed to ocean winds.
- Install the outdoor unit on the side of the building opposite from direct ocean winds.
- Select a location with good drainage.
- Periodically clean dust or salt particles off of the heat exchanger with water.

If the outdoor unit must be placed in a location where it would be subjected to direct ocean winds, install a concrete windbreaker strong enough to block any winds. Windbreaker height and width should be more than 150% of the outdoor unit, and be installed at least 27-1/2 inches away from the outdoor unit to allow for airflow.

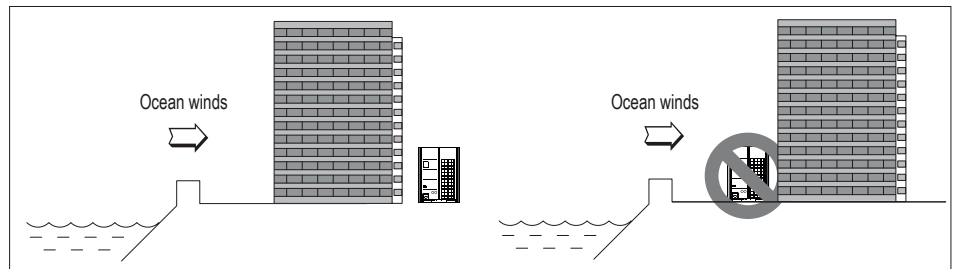

Note:

Additional anti-corrosion treatment may need to be applied to the outdoor unit at oceanside locations.

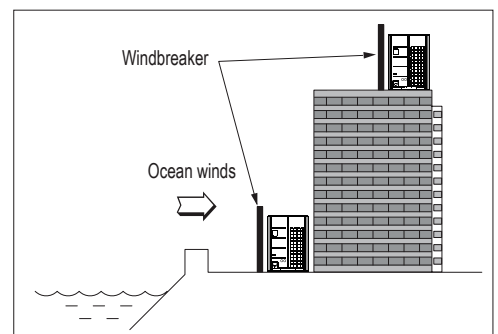

Outdoor Unit Installation Space

Proper airflow through the outdoor unit coil is critical for proper unit operation. When installing the outdoor unit, consider service, inlet, and outlet, and minimum allowable space requirements as illustrated in the diagrams below.

Description	Installation Area	Example No. 1 A ≥ 1" C ≥ 1"	Example No. 2 A and C ≥ 2"
Unit(s) is (are) Enclosed by Four (4) Walls		A ≥ 1" B ≥ 12" C ≥ 1" D ≥ 20"	A ≥ 2" B ≥ 4" C ≥ 2" D ≥ 20"
		A ≥ 1" B ≥ 12" C ≥ 1" D ≥ 20" E ≥ 1"	A ≥ 2" B ≥ 4" C ≥ 2" D ≥ 20" E ≥ 4"
		A ≥ 1" B ≥ 20" C ≥ 1" D ≥ 20" E ≥ 1" F ≥ 36"	A ≥ 2" B ≥ 4" C ≥ 2" D ≥ 20" E ≥ 4" F ≥ 20"
		A ≥ 1" B ≥ 12" C ≥ 1" D ≥ 12" E ≥ 1" F ≥ 20"	A ≥ 2" B ≥ 4" C ≥ 2" D ≥ 4" E ≥ 4" F ≥ 20"
Unit(s) is (are) Facing Away From Each Other (To the Rear)		A ≥ 1" B ≥ 20" C ≥ 1" D ≥ 20" F ≥ 36"	A ≥ 2" B ≥ 20" C ≥ 2" D ≥ 20" F ≥ 24"
		A ≥ 1" B ≥ 20" C ≥ 1" D ≥ 20" E ≥ 1" F ≥ 48"	A ≥ 2" B ≥ 20" C ≥ 2" D ≥ 20" E ≥ 4" F ≥ 36"
		A ≥ 1" B ≥ 20" C ≥ 1" D ≥ 20" E ≥ 1" F ≥ 71"	A ≥ 2" B ≥ 20" C ≥ 2" D ≥ 20" E ≥ 4" F ≥ 48"
Two (2) Sides Are Enclosed By Walls		A ≥ 1" B ≥ 12"	
		A ≥ 8" B ≥ 12" E ≥ 16"	

Piping Limitations and Placement Considerations

Note:

Different clearances are required if a Low Ambient Cooling Kit is installed. Refer to the Low Ambient Cooling Kit Installation Manual for clearance information.



Installing Outdoor Units Indoors

Outdoor Unit Installation Space, continued.

<p>Wall Height Limitations (When the Unit[s] is [are] Surrounded by Four [4] Walls)</p>		<ul style="list-style-type: none"> • Wall height at the front of the outdoor unit must be ≤ 60 inches. • Wall height at the inlet side of the outdoor unit must be ≤ 20 inches. • There are no height limitations for the walls at the sides of the outdoor unit. • If the wall heights at the front and inlet sides of the outdoor unit are higher than allowable limits, additional space must be included. <ul style="list-style-type: none"> - Additional space on the inlet side by $1/2$ of h_1. - Additional space on the front side by $1/2$ of h_2. - $h_1 = A$ (the actual height) - 60. - $h_2 = B$ (the actual height) - 20.
---	--	---

Installing Outdoor Units Indoors

LG Multi V outdoor units are engineered to be mounted outdoors and include technology designed to minimize the negative effects of winter weather's freezing rain, sleet, and snow. Some building projects, however, necessitate placing the HVAC outdoor units indoors:

- Lack of ground space.
- Lack of an appropriate outdoor location that meets system design requirements.
- When mounting on the roof is not an option due to a lack of roof space.
- Roof warranty will be voided if mechanical equipment is placed on the membrane.
- On retrofit projects, a former chiller/boiler/air handler equipment room, mechanical area, or penthouse already exists.
- Where a project has vertical, self-contained VAV air handlers on each floor (in lieu of a centralized mechanical room).
- To curtail the potential need for redundant zone heating devices such as wall-fin radiators or duct heaters.
- In extremely cold environments where there is a significant amount of run-time at temperatures well below freezing outside the outdoor unit ambient air temperature range published in this engineering manual.

Benefits of Installing Outdoor Units Indoors

- Shelters the outdoor unit from direct exposure to prevailing winds that decrease the heating capability of the outdoor unit.
- Protects equipment from freezing precipitation and/or potential ice build-up that could hinder unit operation.
- Maintains coil heat transfer efficiency by reducing the number of and shortening the cycle time for defrost operation.
- Easier maintenance and servicing during inclement weather.
- When mounted in a fully enclosed space, limiting the ambient air temperature may allow the Multi V system designer to eliminate oversizing the outdoor unit to compensate for loss of capacity at low ambient temperatures.
- May also curtail the need to provide inefficient redundant zone heating devices such as wall-fin radiators and second-stage ancillary heating devices.

Design Considerations Include:

- Enclosure types and elements such as louvers, rain hoods, dampers and controls, heating methods and sizing of heating devices
- Heating strategies
- Duct design
- Condensate handling

General Guidelines

- Follow ASHRAE 62.1 design guidelines.
- Depending on the project / application, a roof over the outdoor units in combination with a wind break may be all that is necessary.
- Consider the potential for snow accumulation near louvers/roof openings. Outside air intakes and discharge ducts/louvers should be engineered to clear anticipated snow accumulation levels by at least one (1) foot.
- In situations where operation is anticipated at temperatures of -13°F and lower, auxiliary heat should be provided to heat the outdoor unit coils to assure continuous compressor operation and heating.

It may be necessary to use an air guide accessory to prevent discharge air from short-cycling back to the coil inlet.

- Another option is to field manufacture duct work and mount on top of the unit to encompass the outdoor unit fan discharge and connect to the exterior discharge grille on the building.
- Avoid using a single duct on multi-fan units to prevent short cycling. Provide a dedicated duct for each outdoor unit fan discharge.
- Consider the direction of prevailing winds and opening placement. If possible, locate inlet openings upwind of discharge openings and other exhaust outlets.
- When inlet and outlet openings are placed on the same wall, minimum distance between the two openings should be approximately three (3) feet (minimum distance varies significantly with variations in outlet opening face velocity).
- If roof-mounted ventilation openings are used, strategically locate the inlet ventilation opening(s) upwind of the outlet opening(s).
- Discharge and supply duct work should be designed to avoid weather related long periods of water entrainment and the potential for microbial growth.

Provide a means to drain the condensate generated during heating mode and defrost cycle in addition to rainwater that infiltrates the inlet louver enclosed area.

- Install a field-provided drain pan under the outdoor units and provide a path to a nearby floor drain.
- If the ambient air temperature is expected to drop below 32°F in the enclosure, heat the bottom surface of the pan, drain line, and floor drain so that the condensate does not freeze before reaching the drain.

Allow for ventilation intake and exhaust air based on maximum outdoor unit fan capacity.

- Select the size, type and orientation of architectural louvers with adequate “net free area” face velocity to ensure the total external static pressure from the outdoor unit fan does not exceed design limitations (see specification data tables).
- No obstructions should be placed in front of the louver that could hamper the free flow (throw) of air.
- Roof top openings and / or discharge and supply louvers should be equipped with screens to prevent bird and insect infiltration.

As always, the best solution for each project balances acceptable heating performance (considering local weather conditions), capital costs, life cycle energy consumption, and limitations set forth by local building codes. For more detailed information on how to design indoor spaces for LG Multi V outdoor units, see the white paper “Air-Source VRF Mechanical Room Design Considerations for Outdoor Unit Placement in Enclosures” on www.lghvac.com.

Note:

For detailed placement considerations and installation requirements for indoor units, refer to its Indoor Unit Engineering and / or Installation Manuals.

To access additional technical documentation such as submittals, indoor unit engineering manuals, installation, service, product data performance, general best practice, and building ventilation manuals, as well as white papers, catalogs, LATS software programs, and more, log in to www.lgvrf.ca

Inverter



LG Electronics, Canada, Inc.
Air Conditioning and Energy Solutions
20 Norelco Drive
North York, ON, Canada, M9L2X6
www.lgvrf.ca

Supersedes: EM_MultiV5_OutdoorUnits_575V_08_18
EM_MultiV5_OutdoorUnits_575V_11_18
EM_MultiV5_OutdoorUnits_575V_12_18